



US 20180170493A1

(19) **United States**

(12) **Patent Application Publication**  
**TERADA**

(10) **Pub. No.: US 2018/0170493 A1**

(43) **Pub. Date: Jun. 21, 2018**

(54) **AQUATIC VESSEL AND PADDLE**

*A63B 35/10* (2006.01)

(71) Applicant: **YAMAHA HATSUDOKI**  
**KABUSHIKI KAISHA, Iwata (JP)**

*A63B 35/12* (2006.01)

(52) **U.S. Cl.**  
*B63B 35/66* (2006.01)

(72) Inventor: **Kohei TERADA, Iwata (JP)**

CPC ..... *B63B 35/7943* (2013.01); *B63C 11/46*

(2013.01); *B63B 35/665* (2013.01); *A63B*

*35/12* (2013.01); *A63B 35/10* (2013.01)

(73) Assignee: **YAMAHA HATSUDOKI**  
**KABUSHIKI KAISHA**

(21) Appl. No.: **15/878,088**

(57) **ABSTRACT**

(22) Filed: **Jan. 23, 2018**

**Related U.S. Application Data**

(63) Continuation-in-part of application No. 15/383,053,  
filed on Dec. 19, 2016.

An aquatic vessel basically includes a floating body, a submersible propulsion unit and a communication device. The floating body has an above water level surface and a below water level surface. The submersible propulsion unit is disposed on the floating body beneath the below water level surface of the floating body. The communication device is disposed on the floating body above the above water level surface of the floating body. The communication device is wired to the submersible propulsion unit, and is configured to wirelessly communicate with a control module.

**Publication Classification**

(51) **Int. Cl.**  
*B63B 35/79* (2006.01)  
*B63C 11/46* (2006.01)

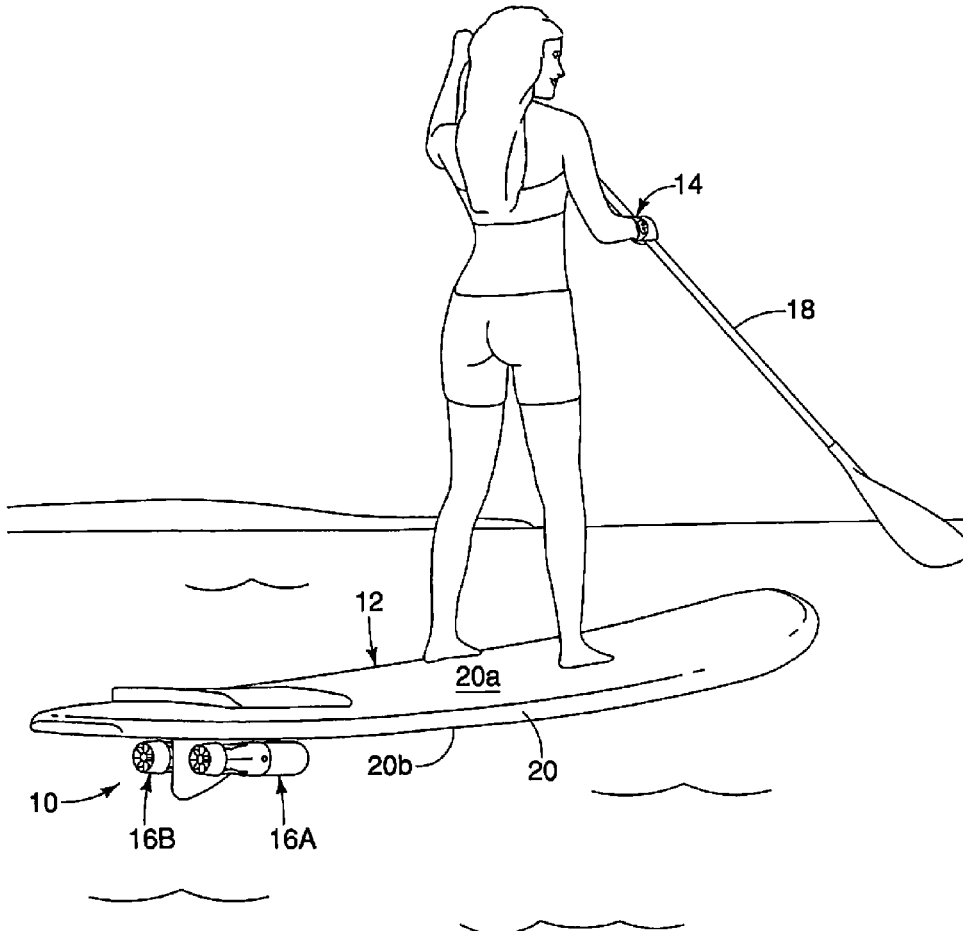

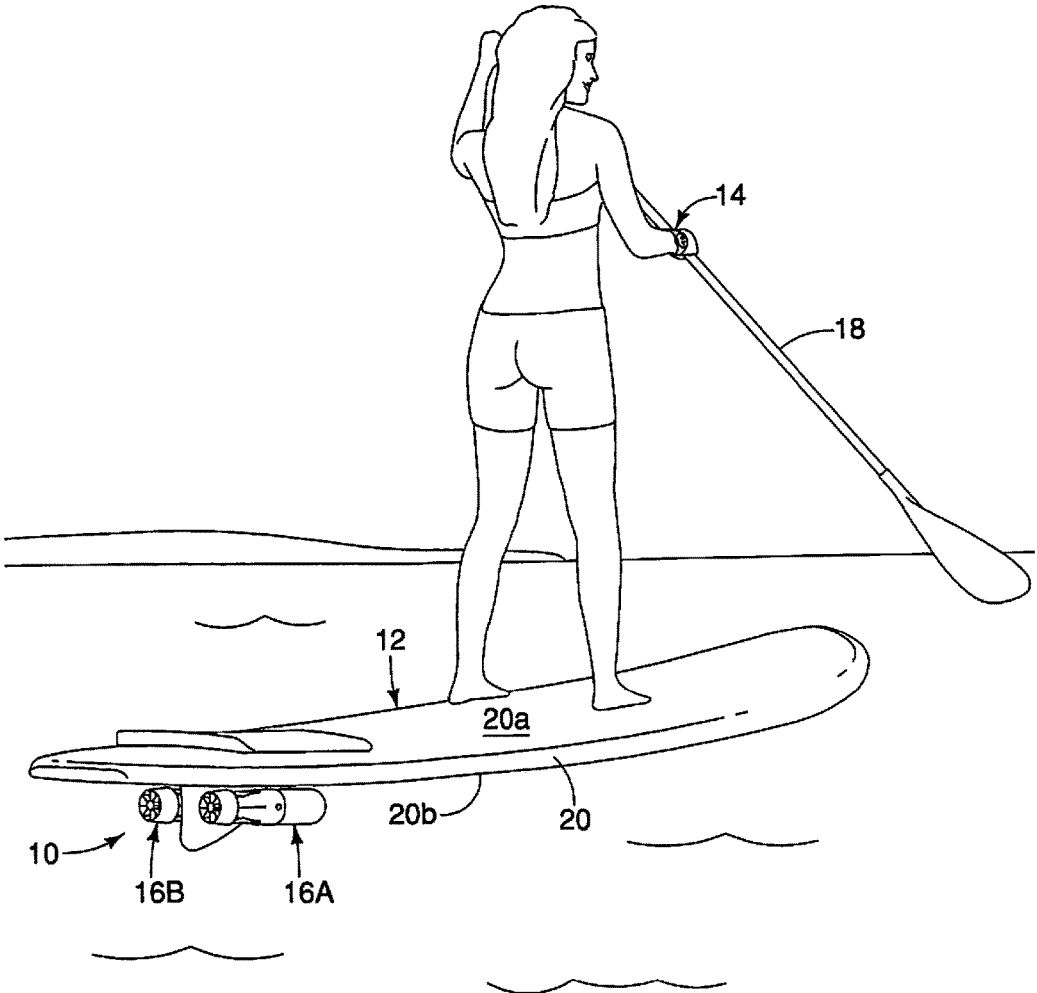

FIG. 1

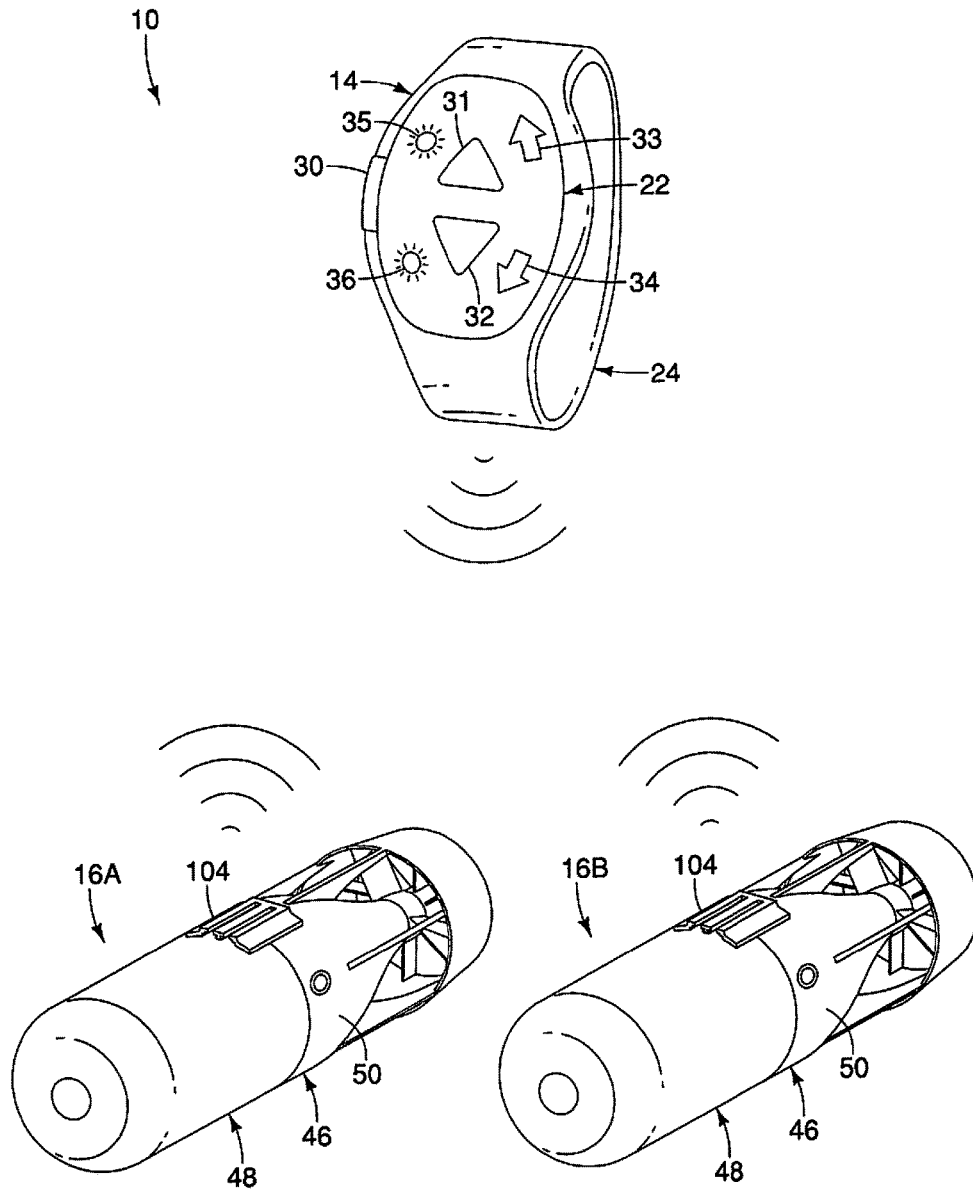

FIG. 2

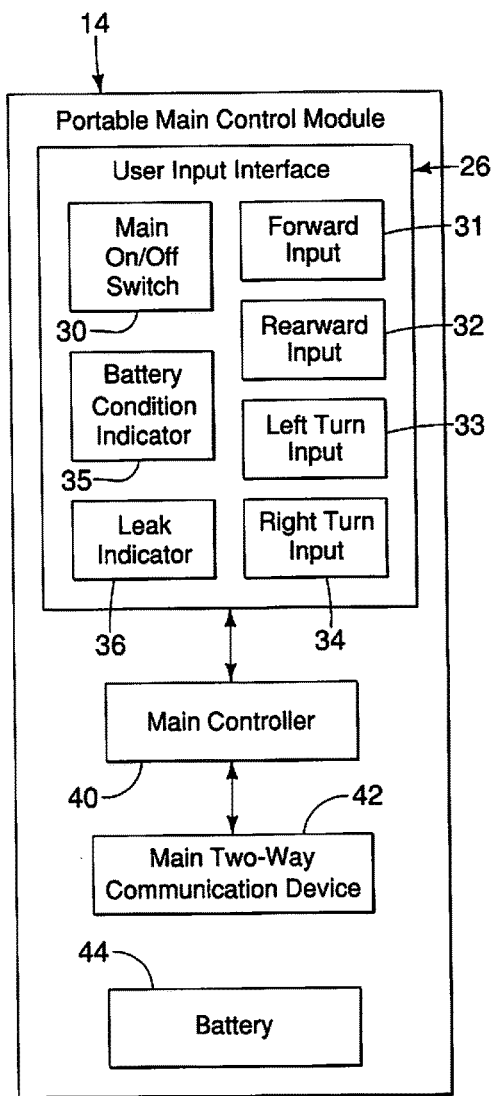

FIG. 3

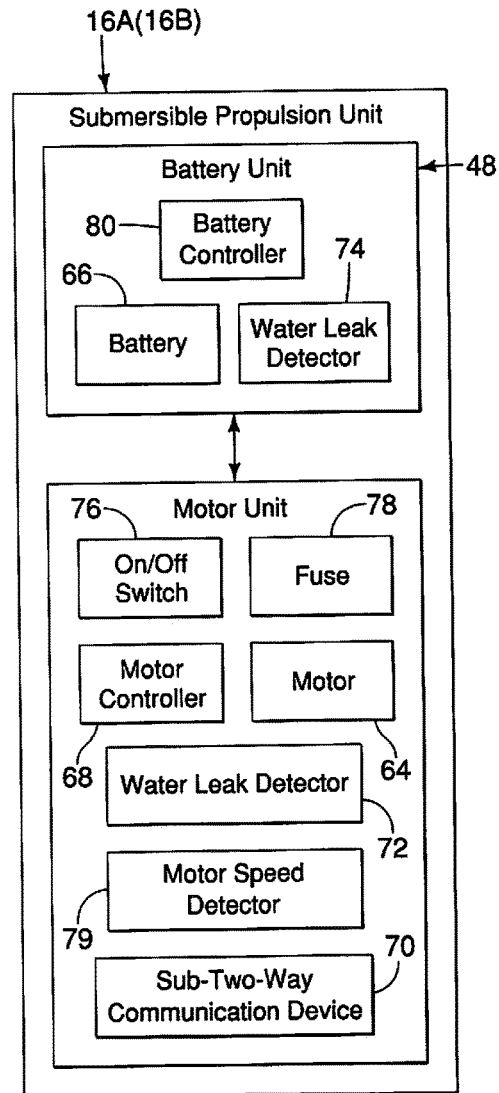

FIG. 4

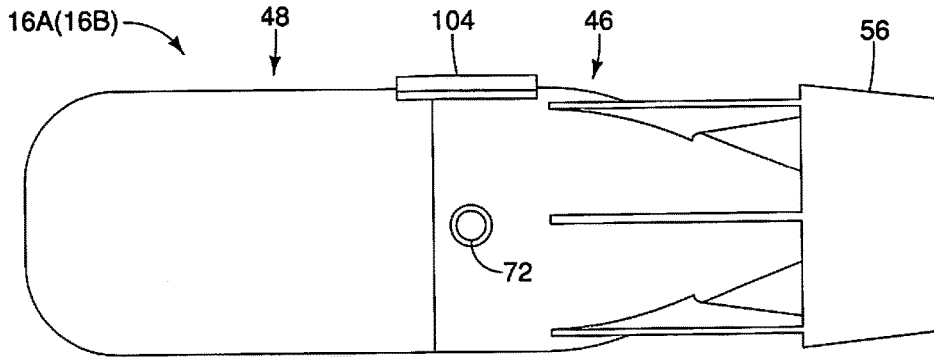

FIG. 5

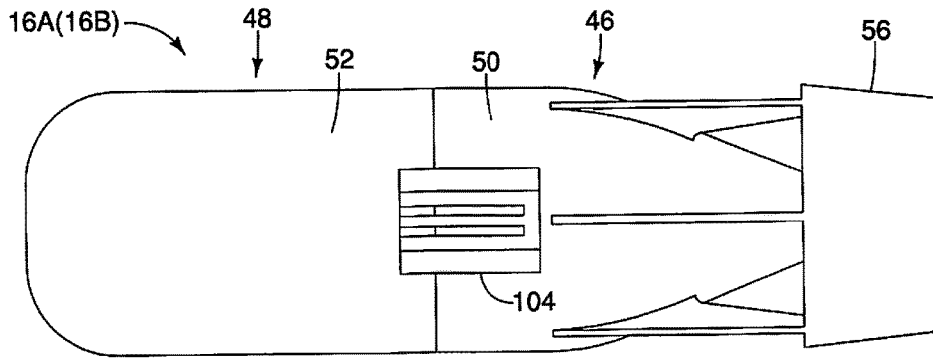

FIG. 6

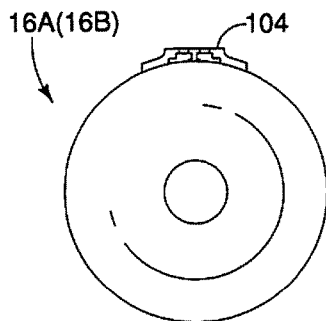

FIG. 7

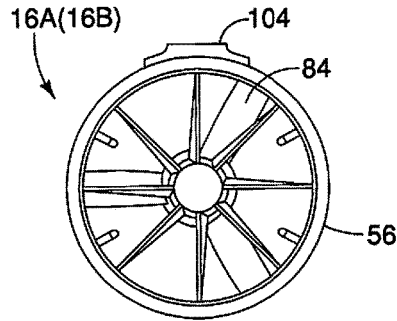

FIG. 8

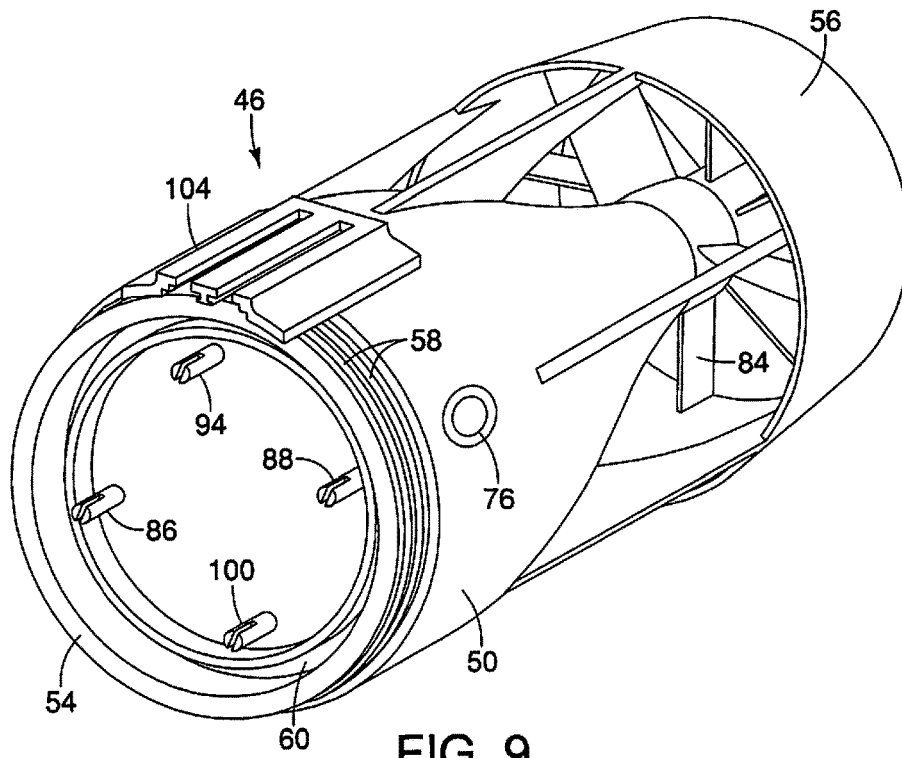

FIG. 9

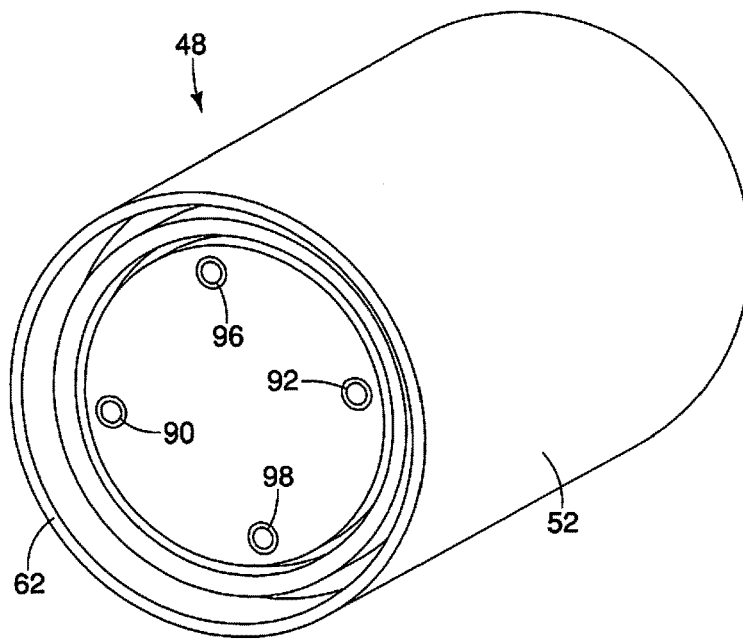

FIG. 10

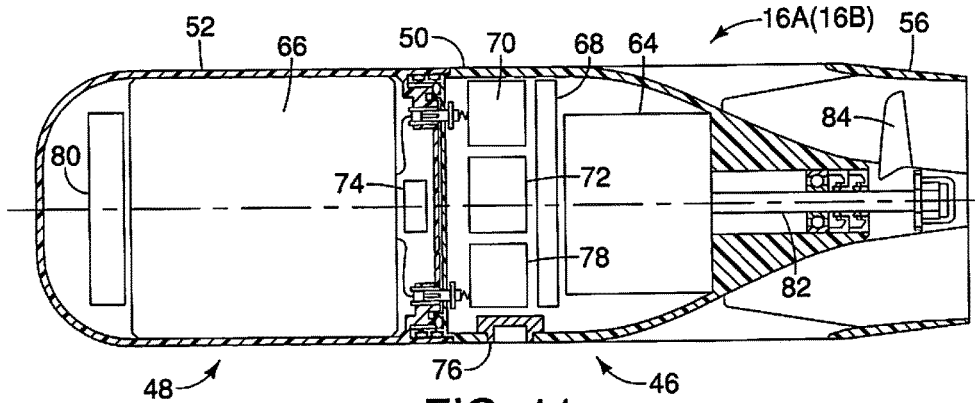

FIG. 11

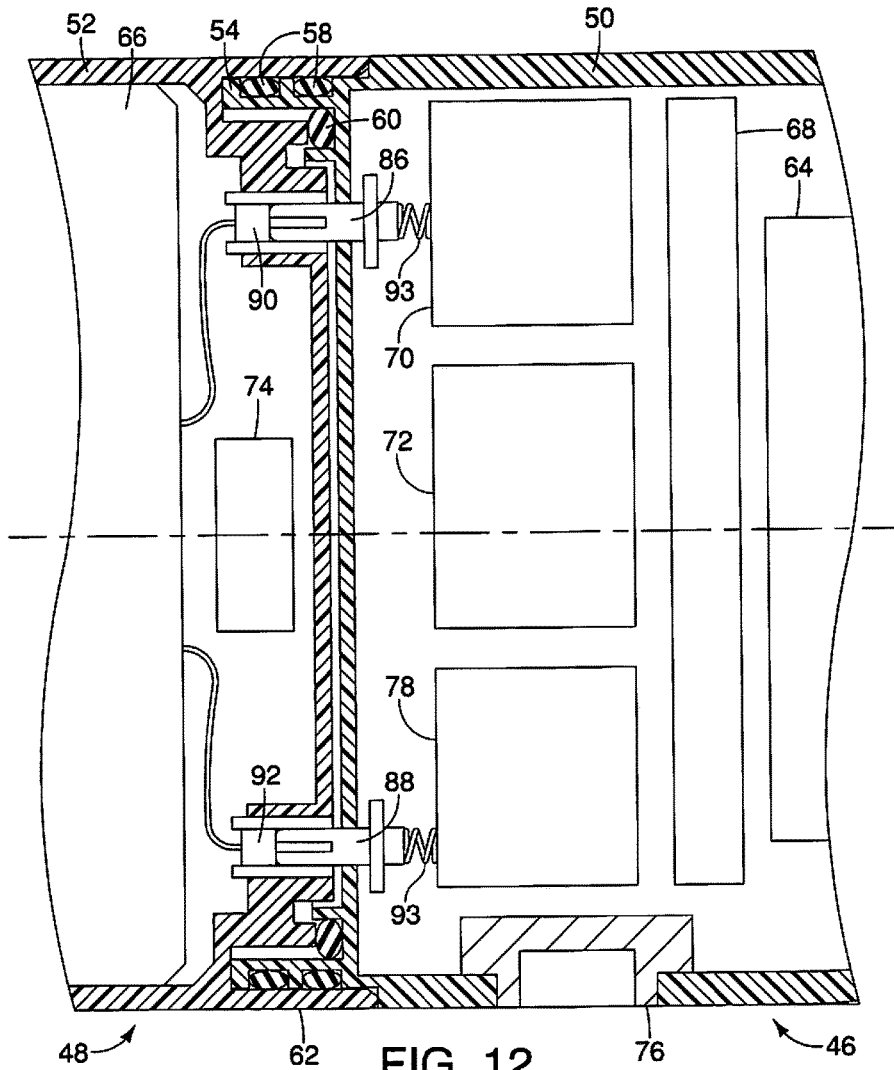

FIG. 12

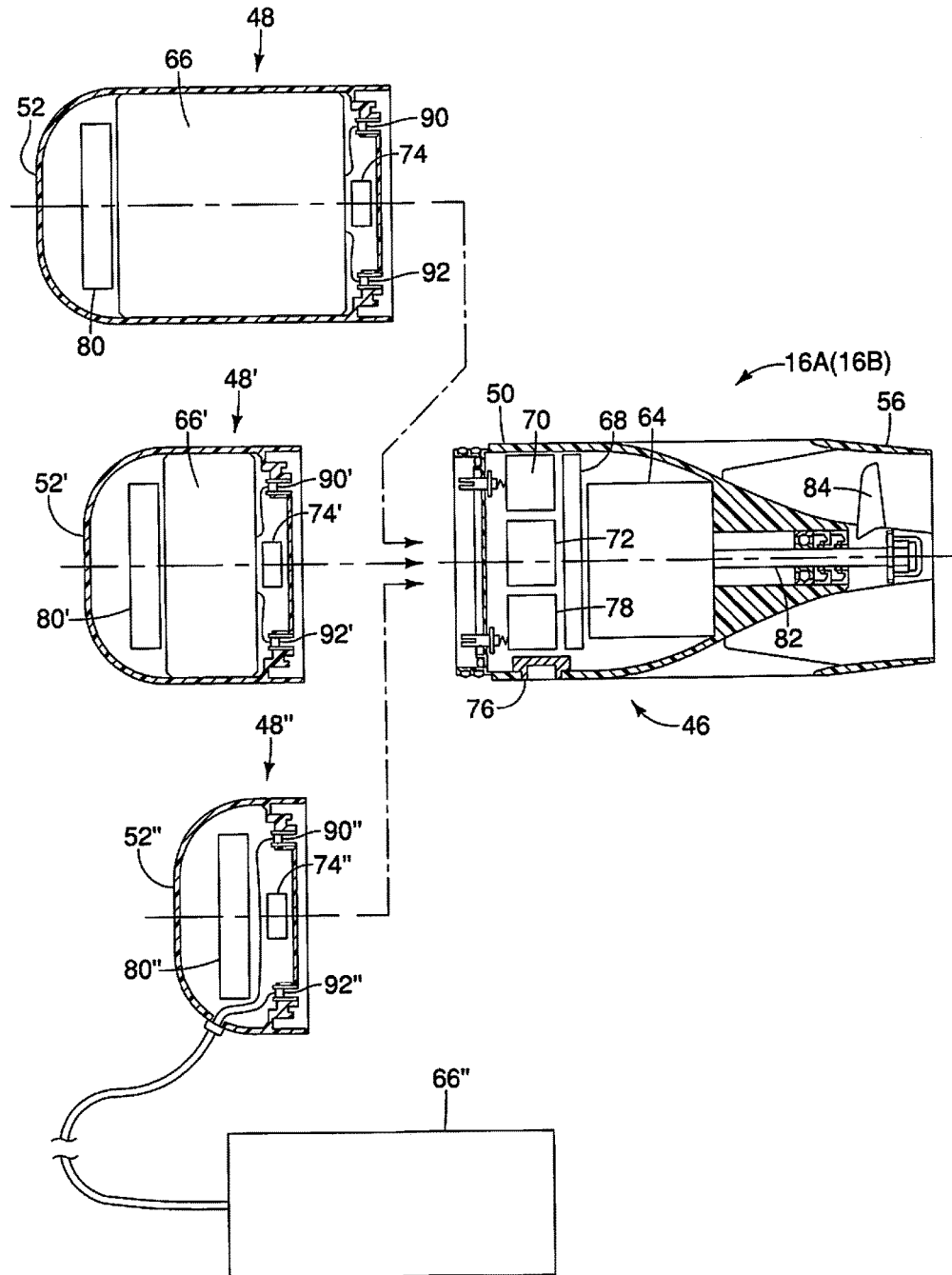

FIG. 13



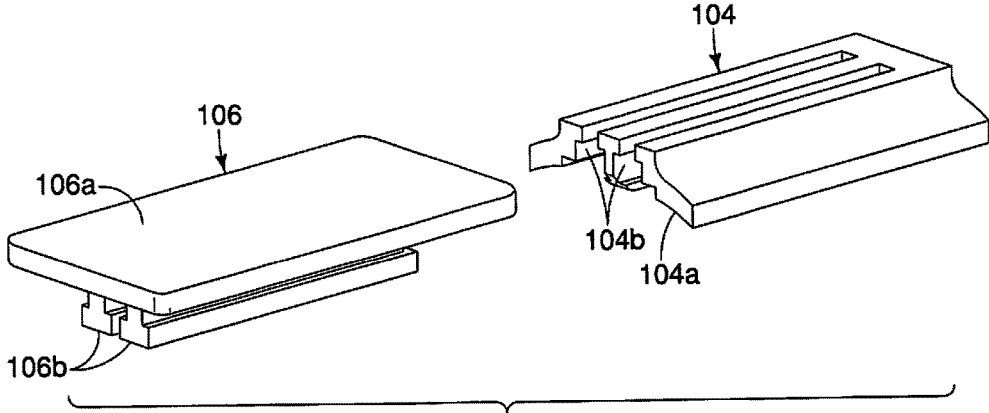

FIG. 14

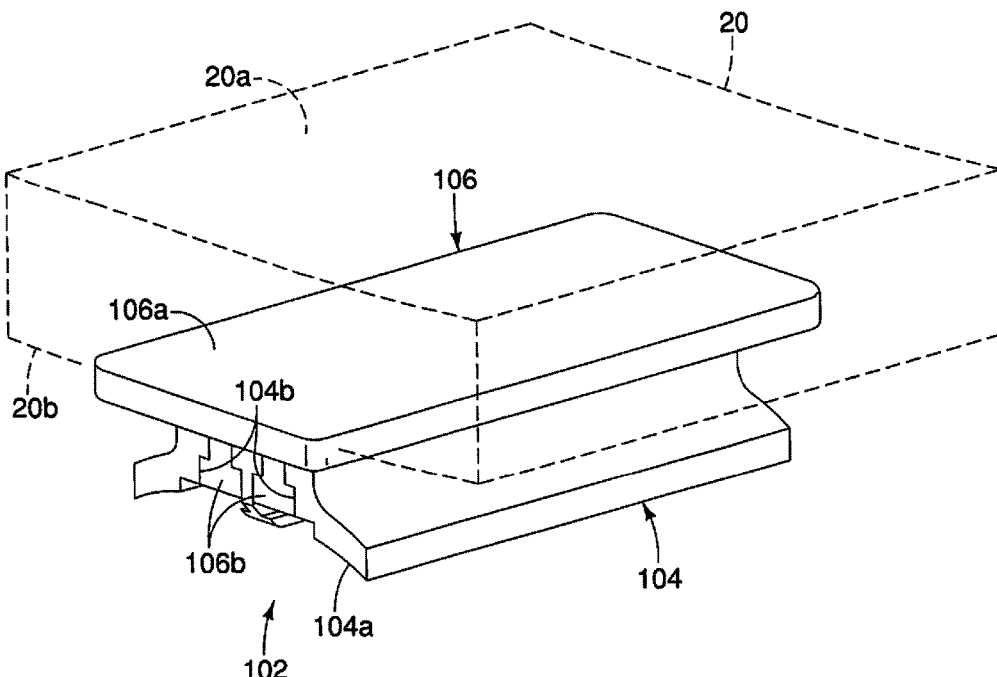

FIG. 15

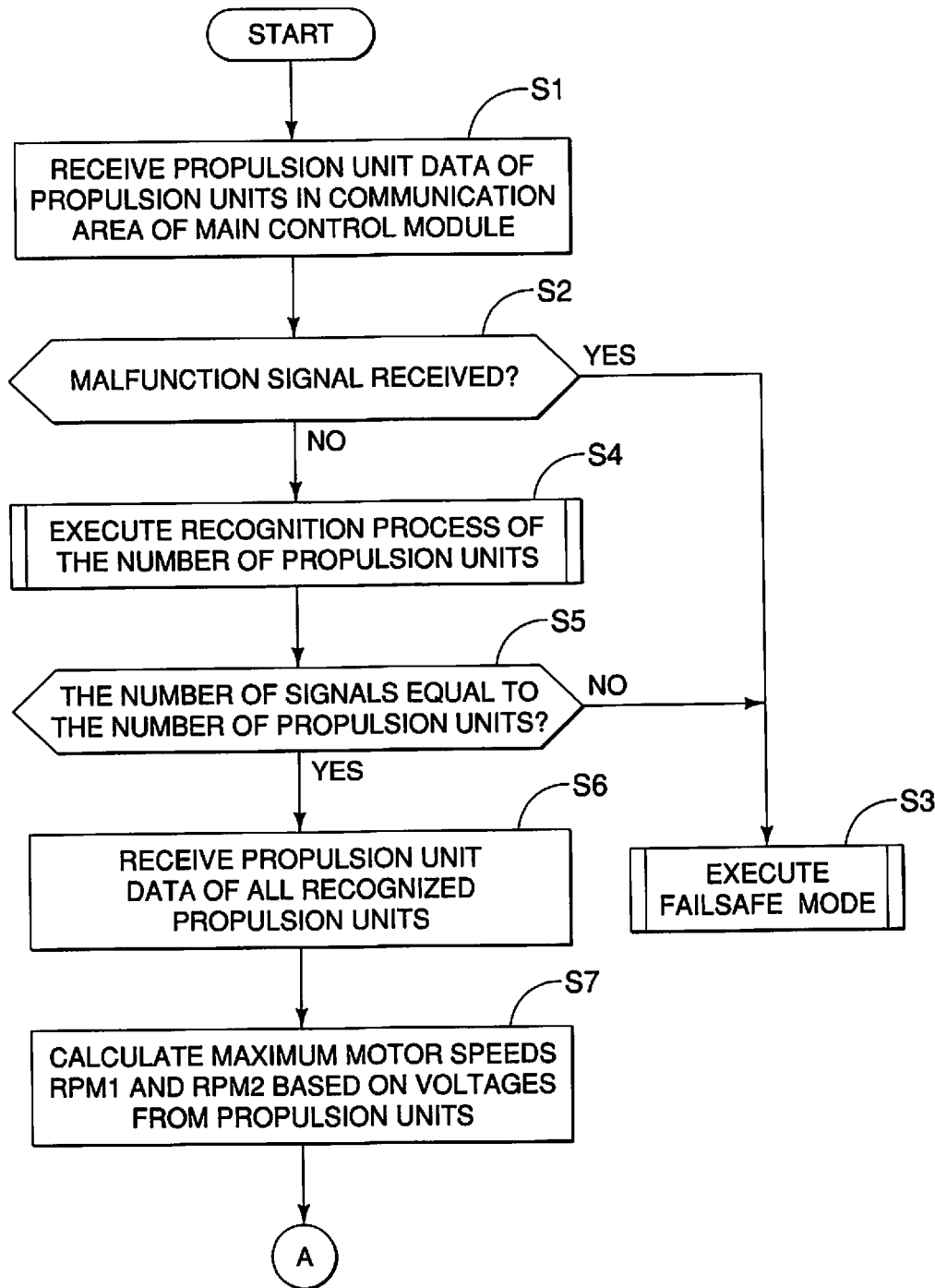

FIG. 16

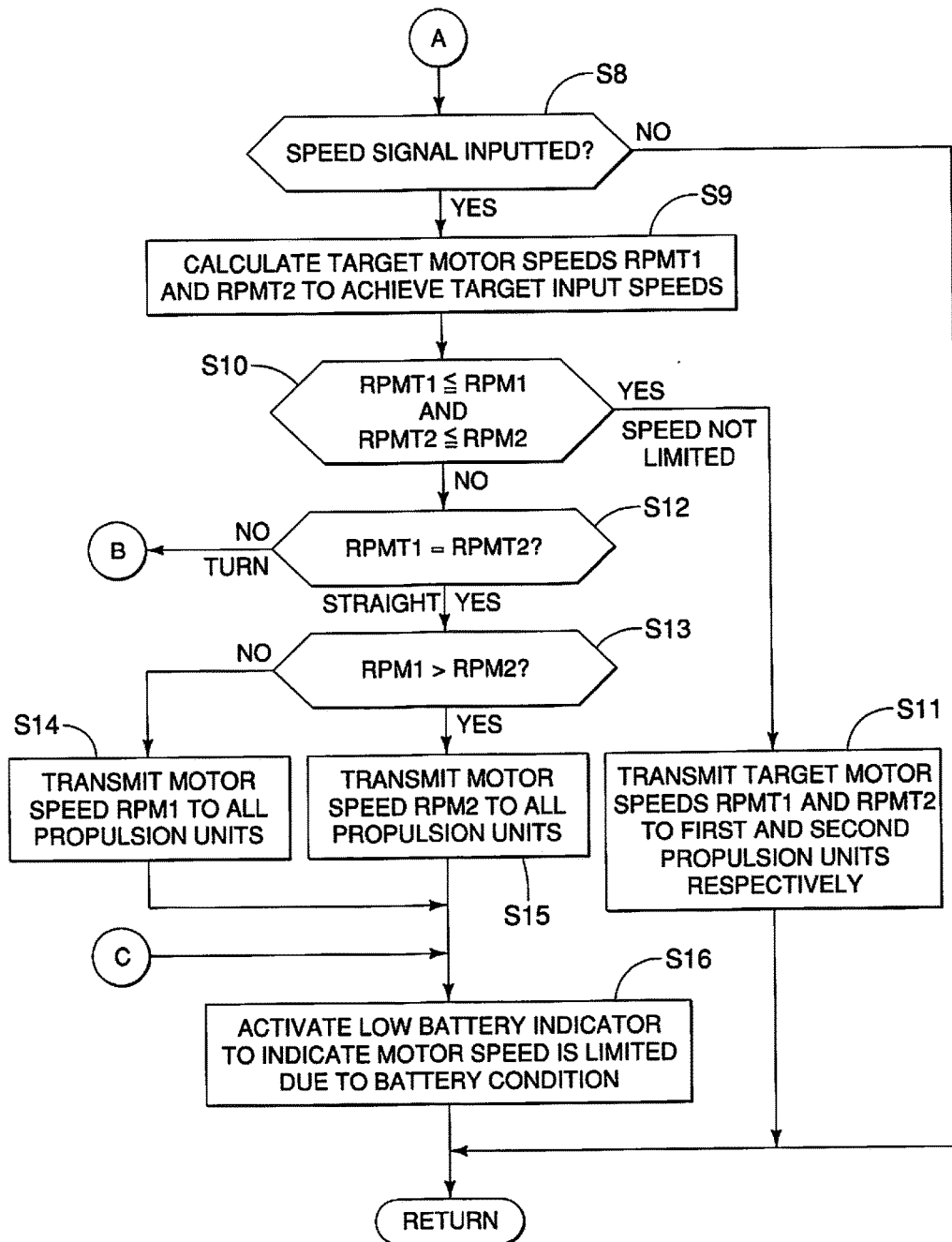

FIG. 17

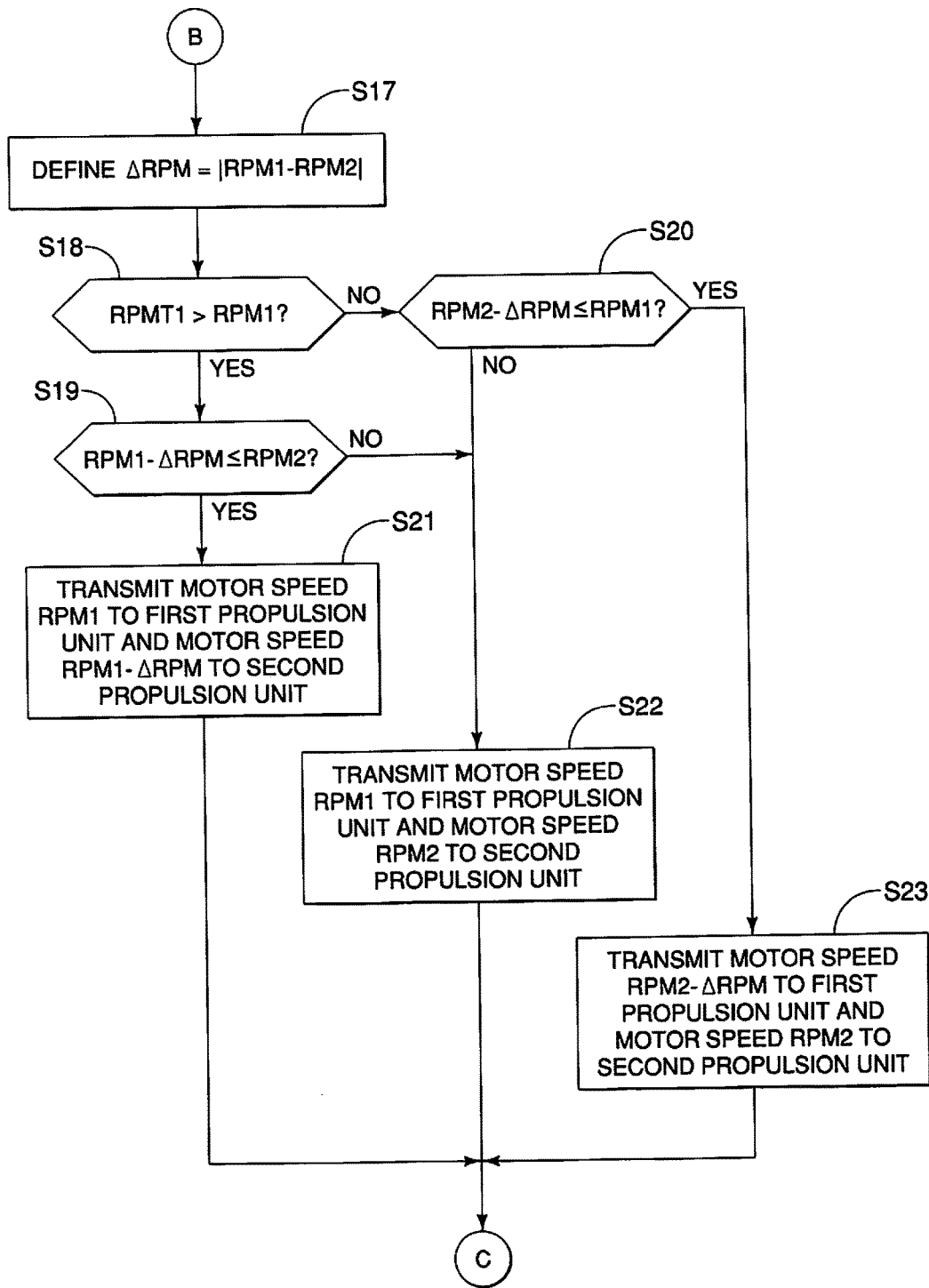

FIG. 18

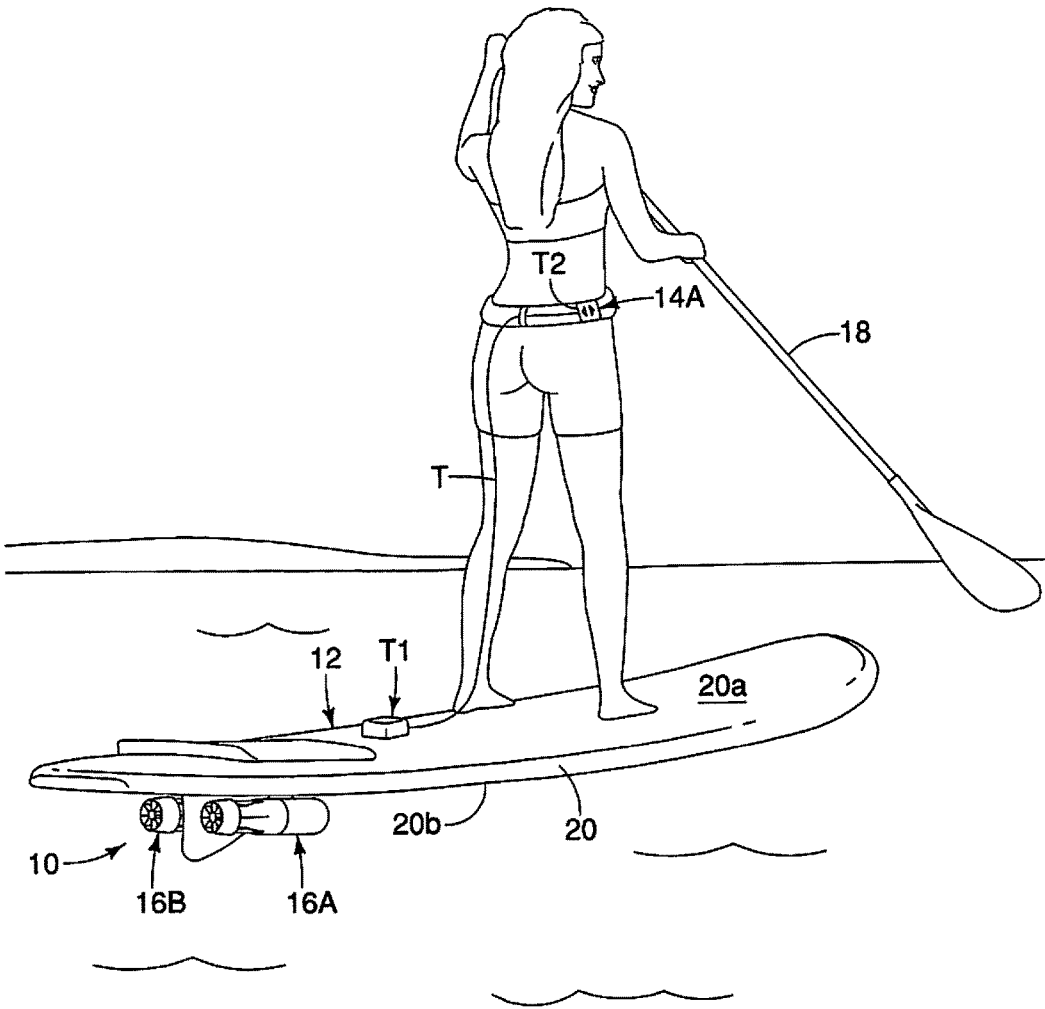

FIG. 19

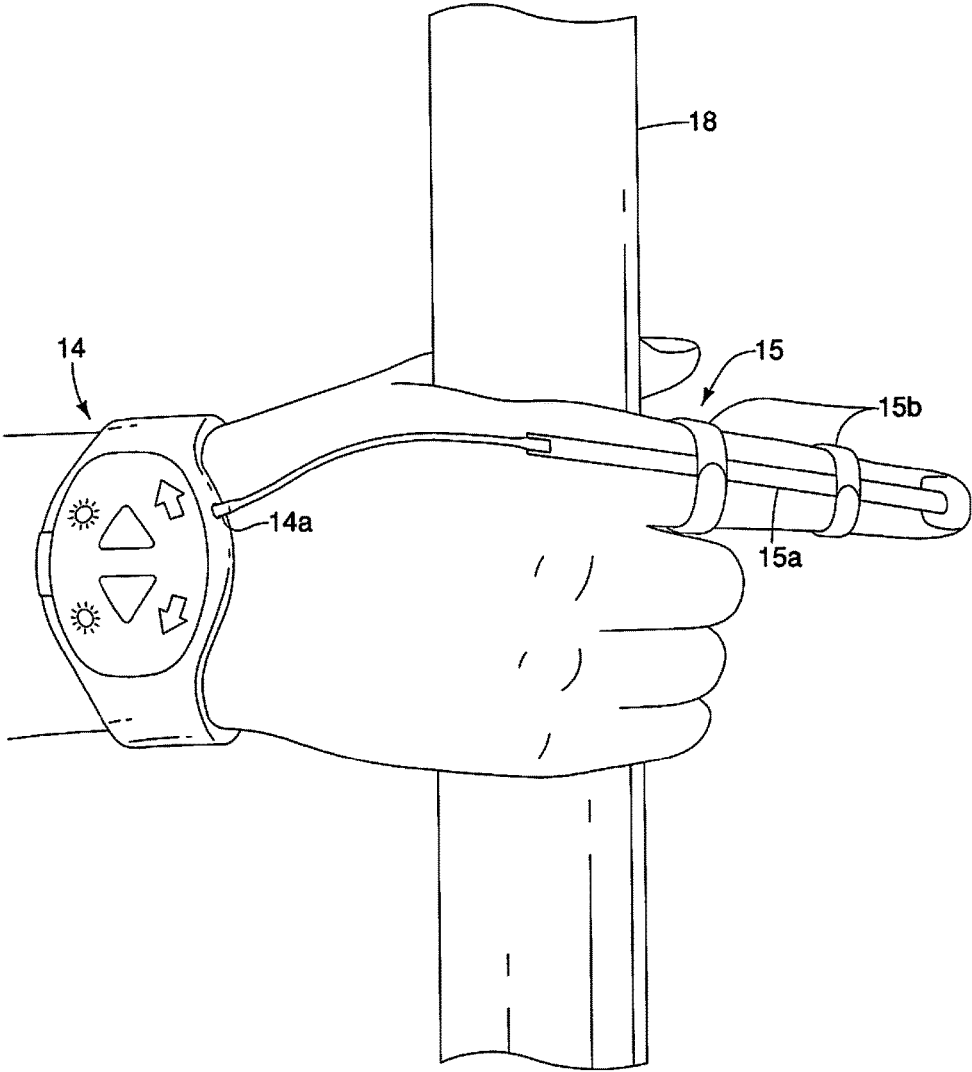

FIG. 20

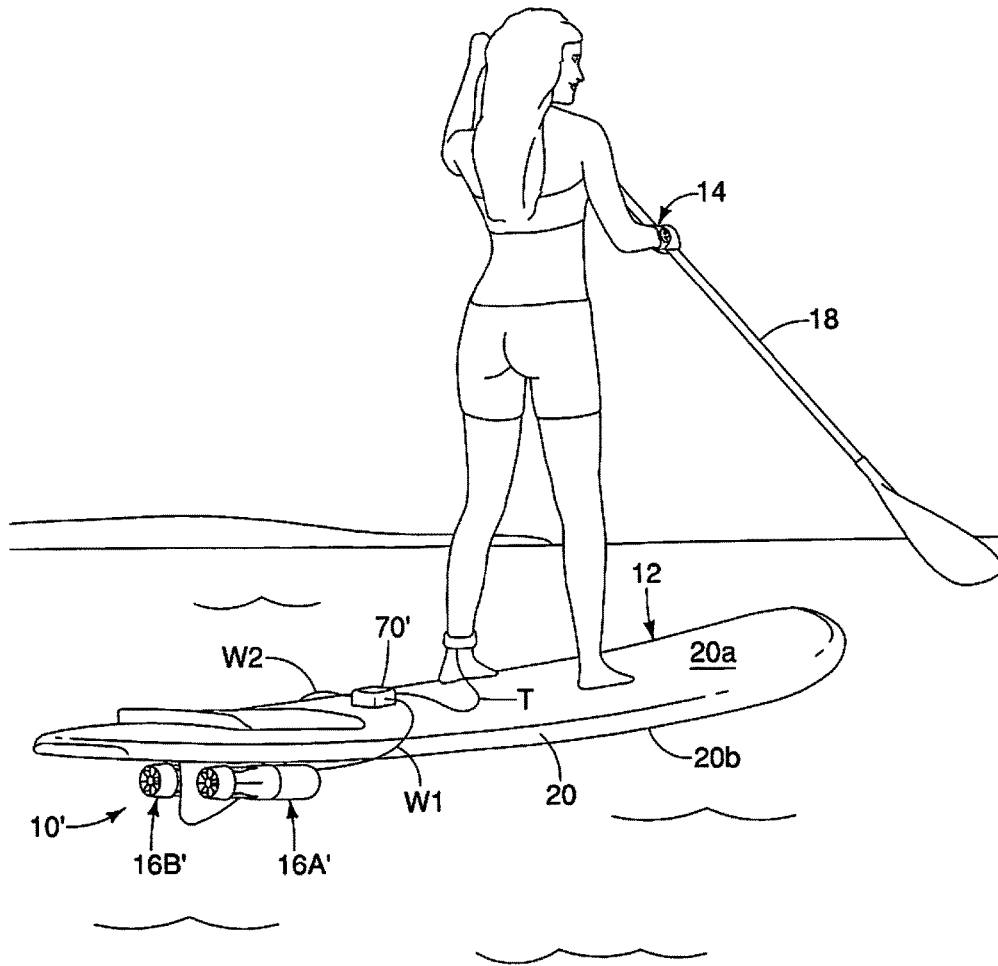

FIG. 21

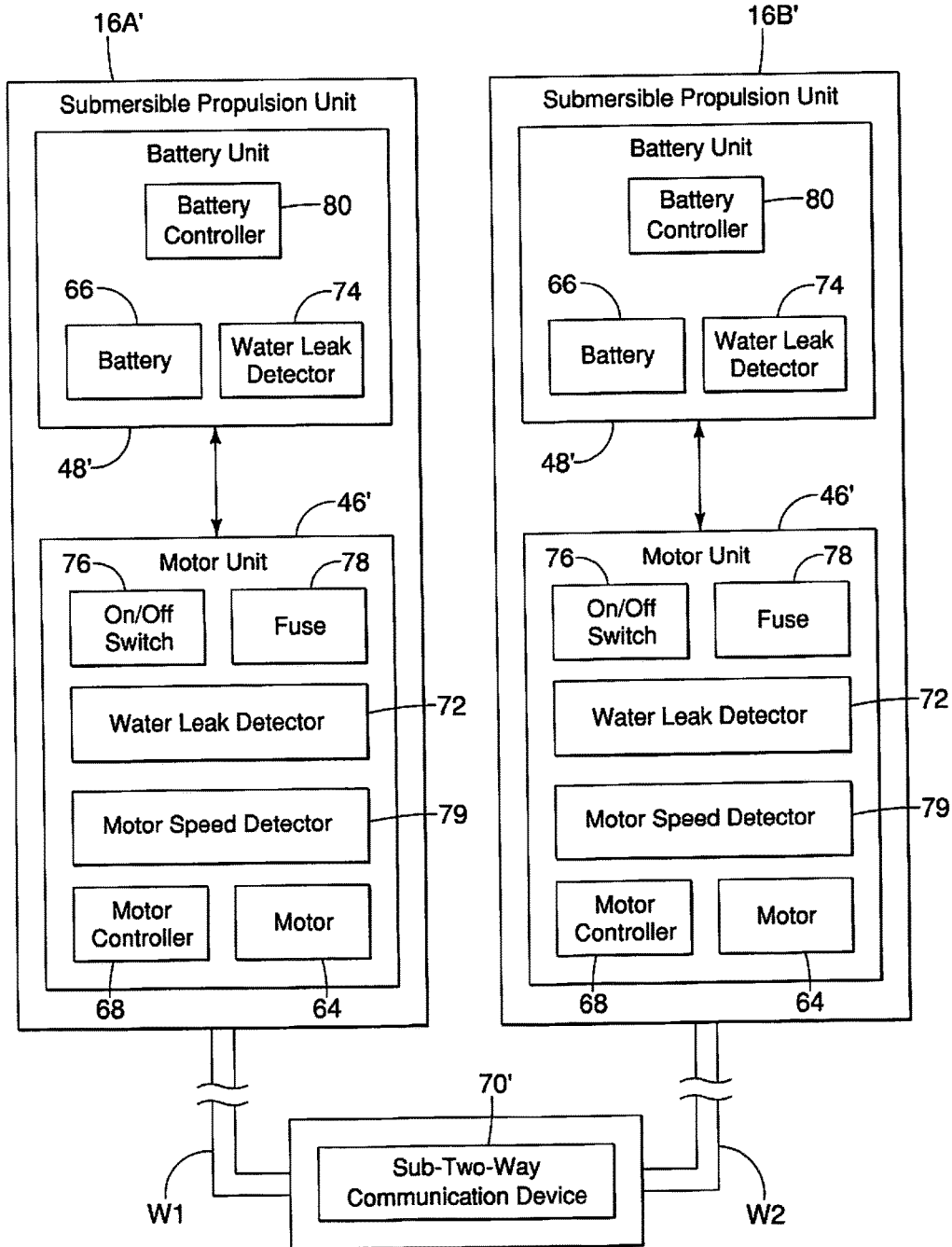

FIG. 22



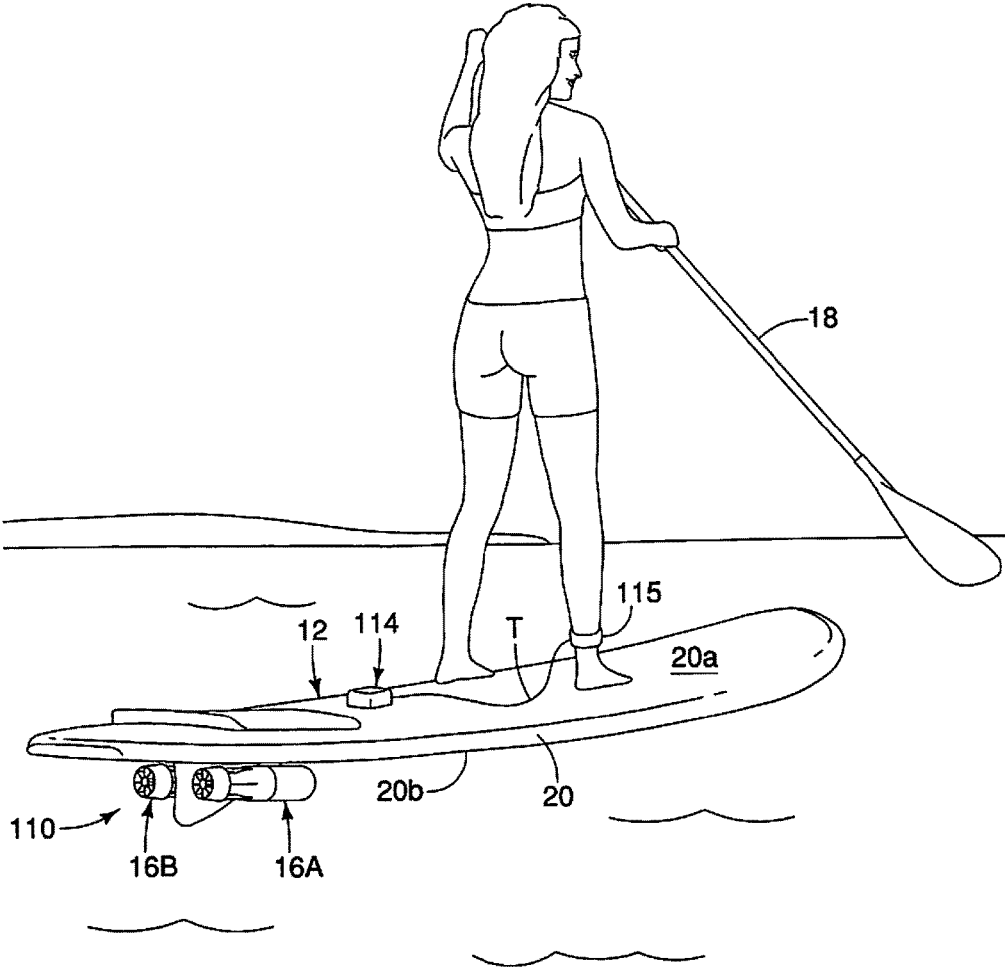

FIG. 23

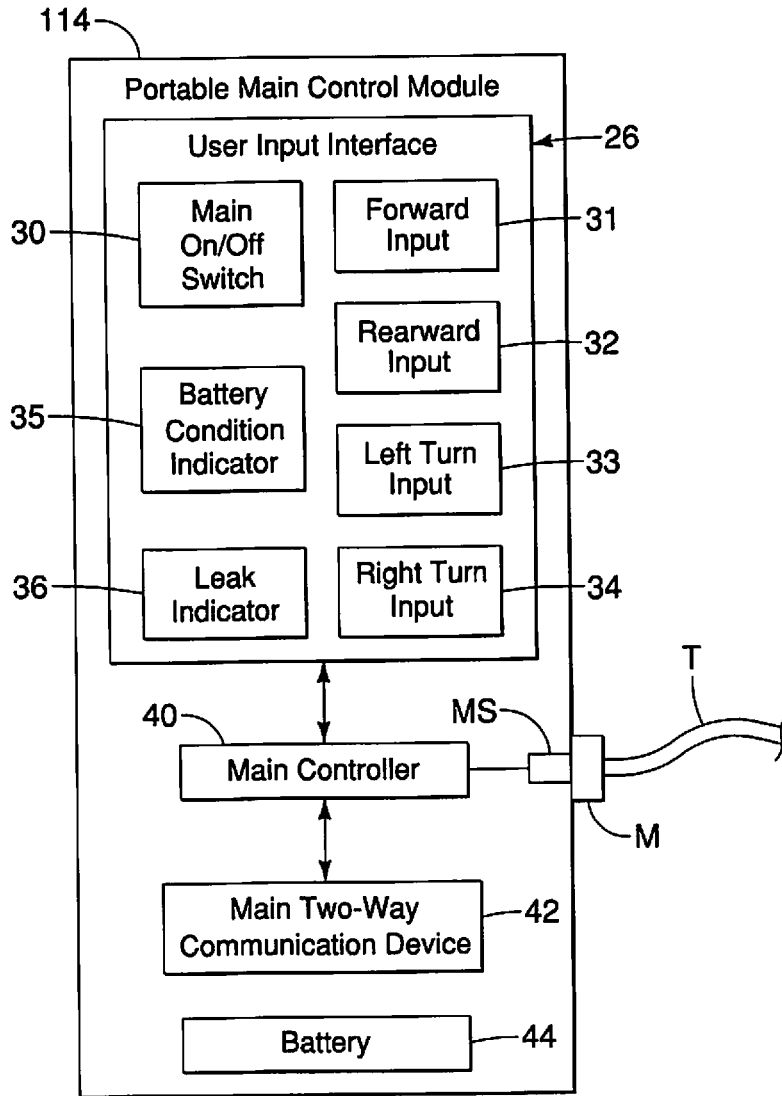

FIG. 24

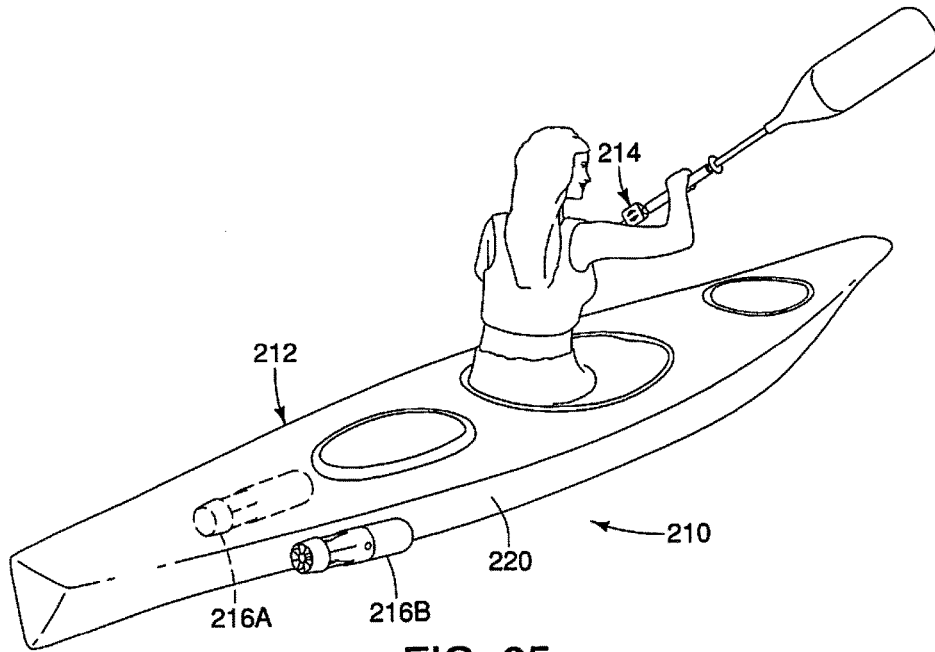

FIG. 25

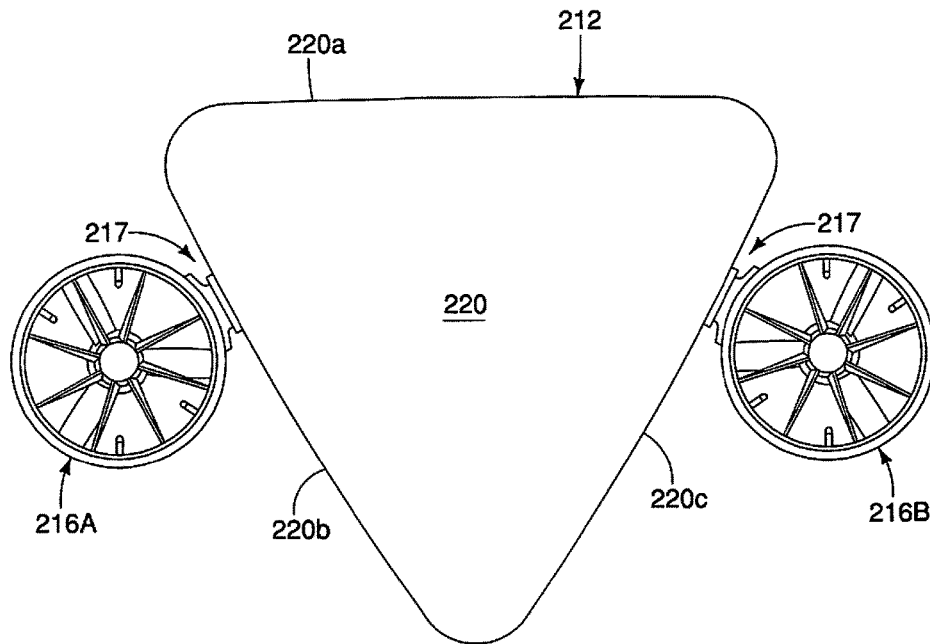

FIG. 26

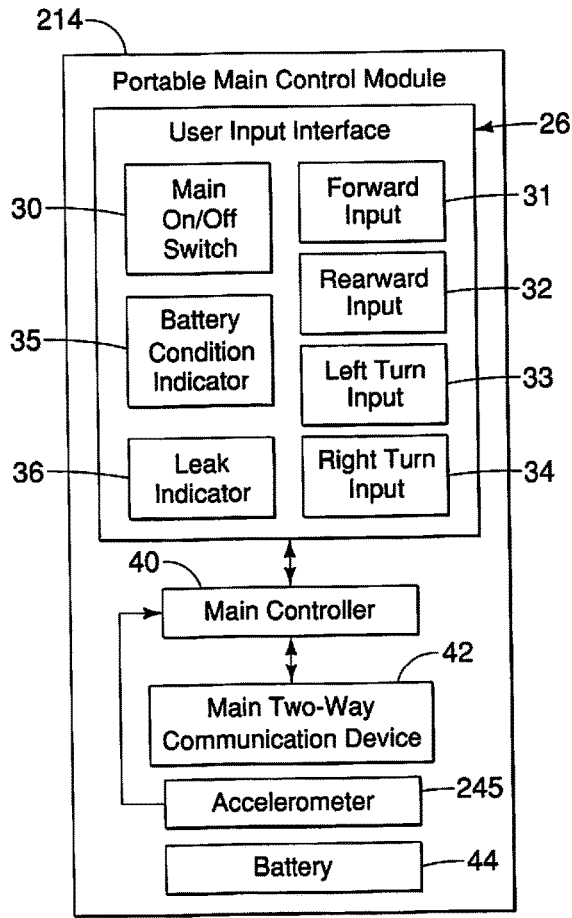

FIG. 27

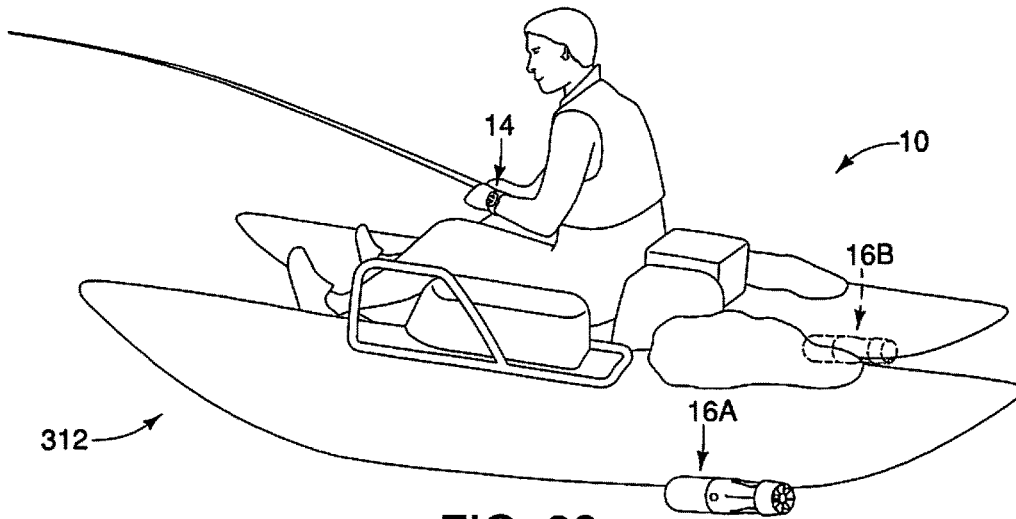

FIG. 28

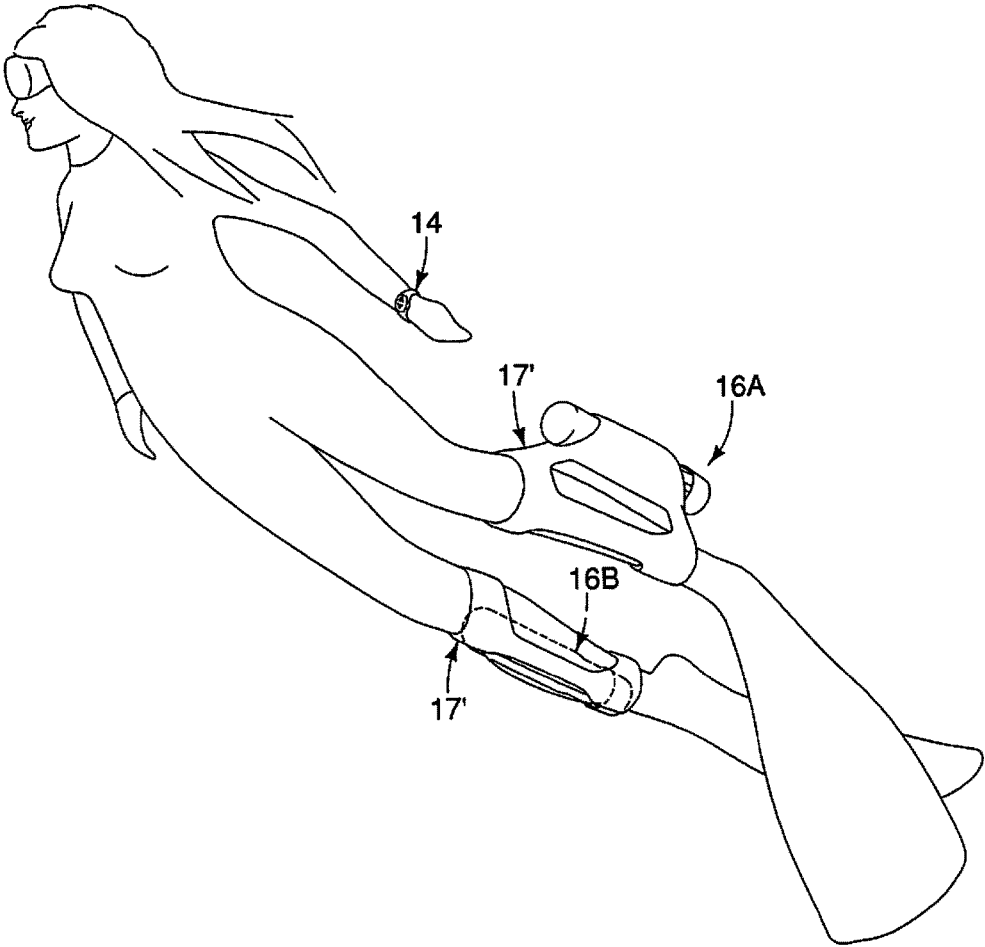

FIG. 29

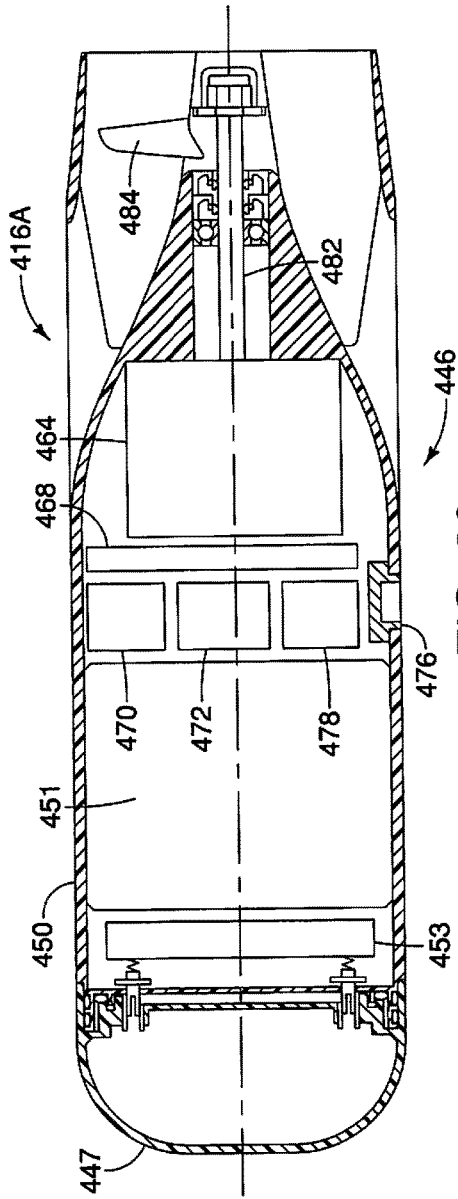

FIG. 30

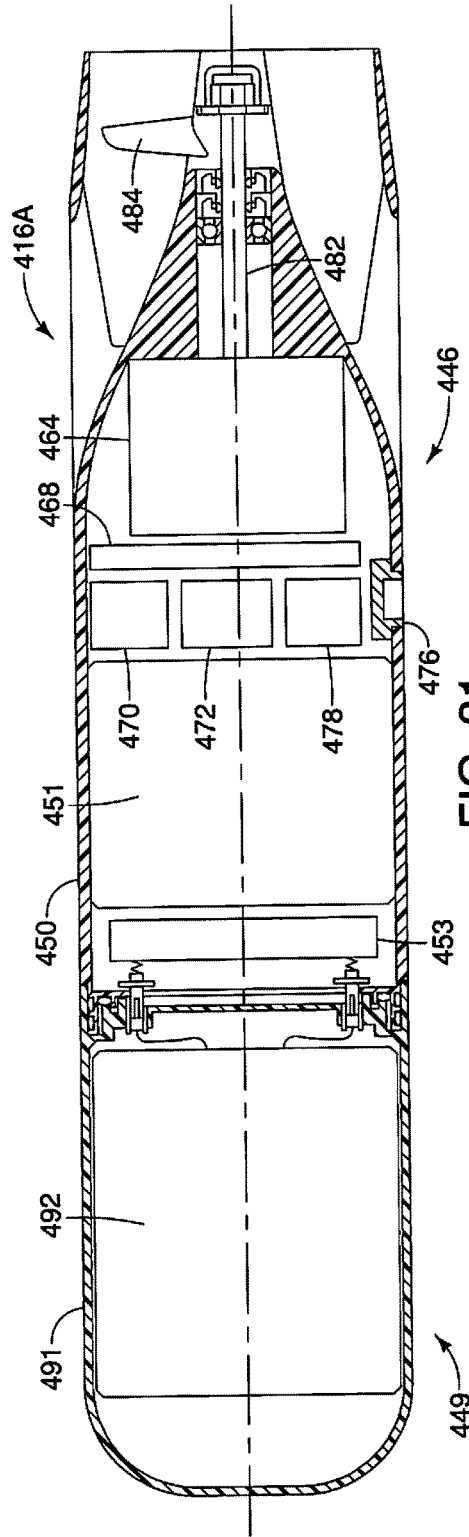

FIG. 31

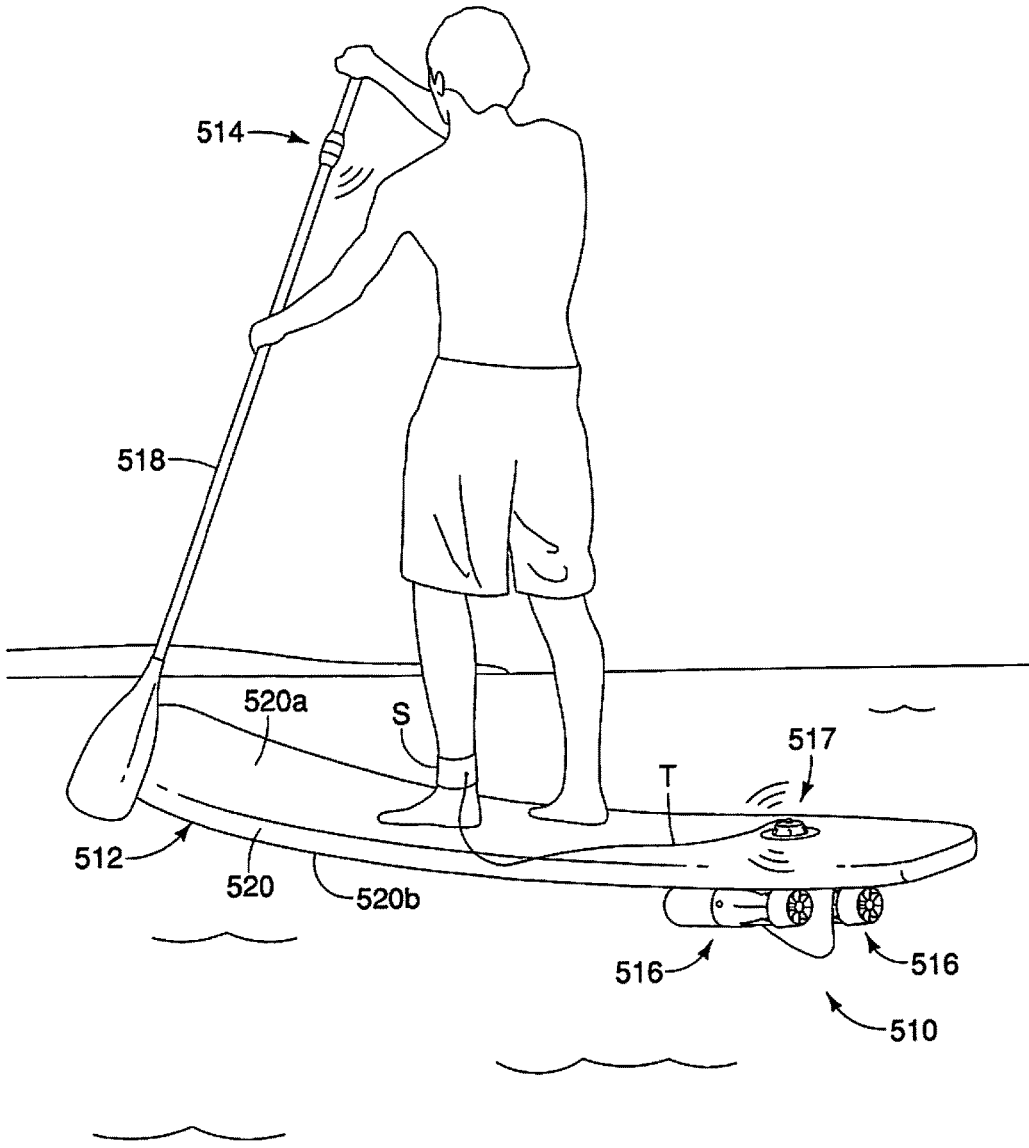

FIG. 32

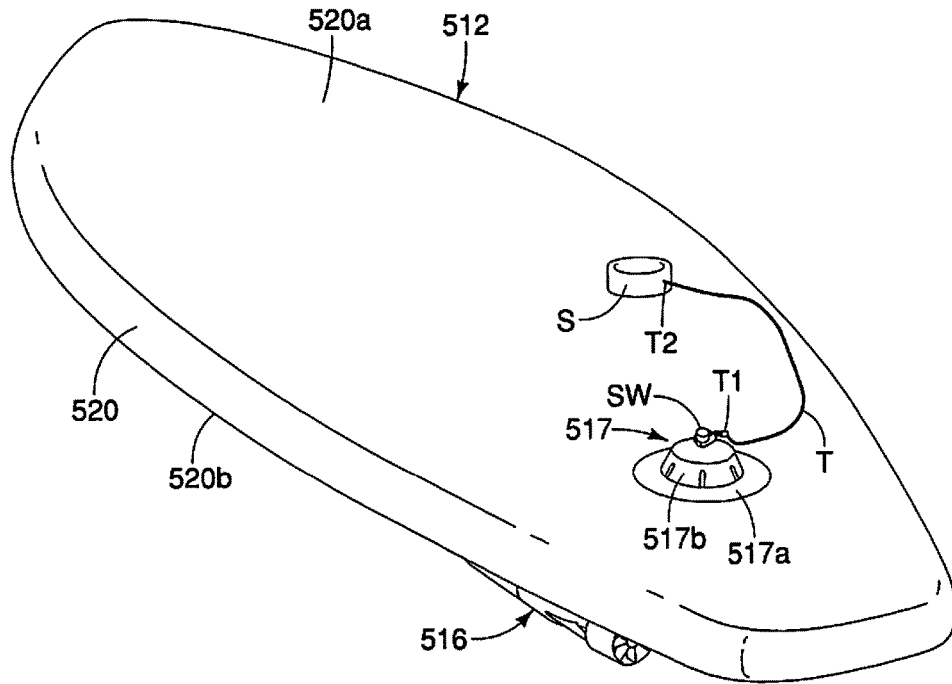

FIG. 33

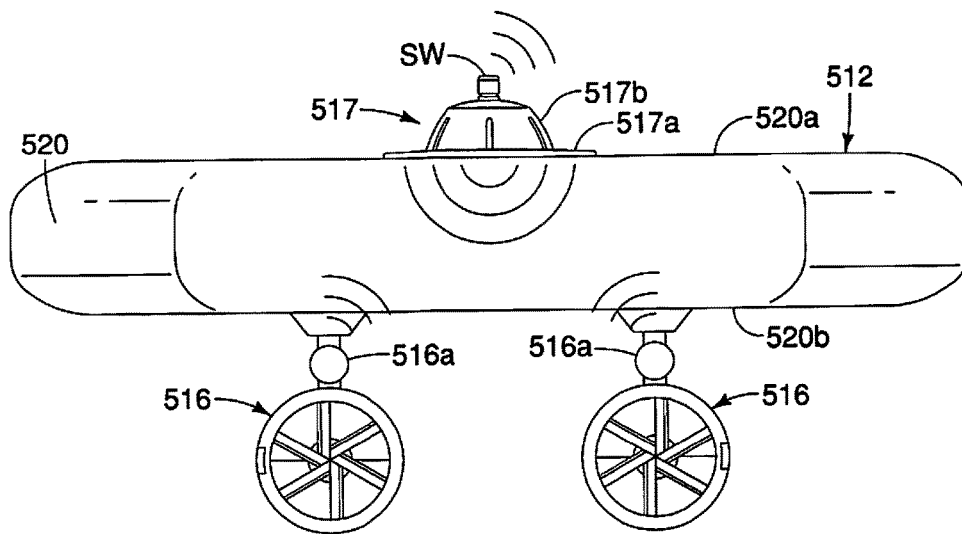

FIG. 34



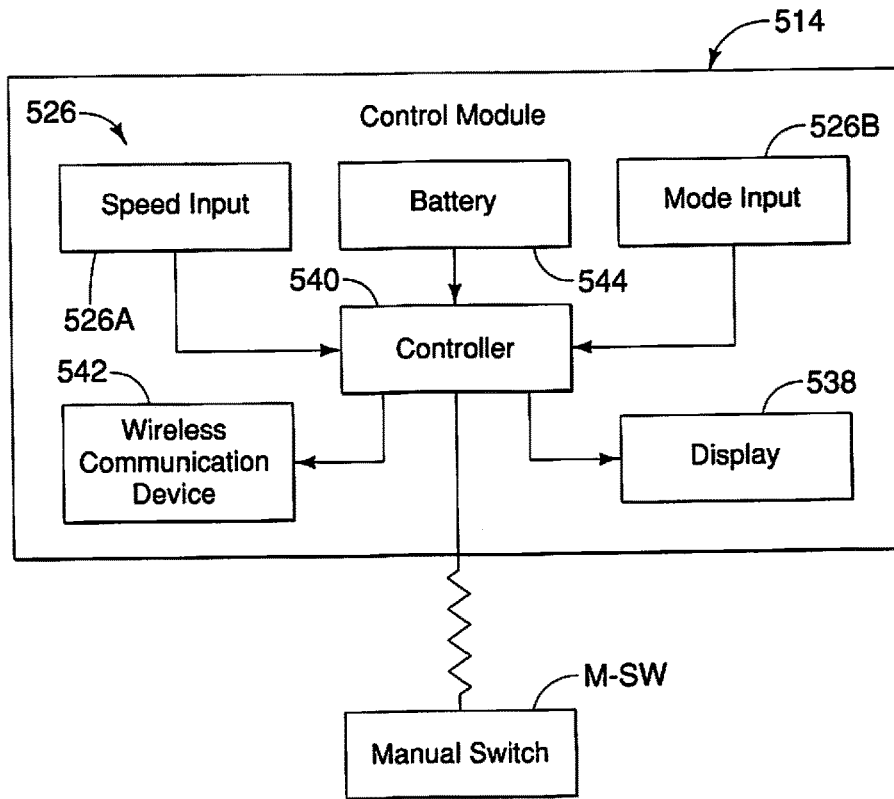

FIG. 35

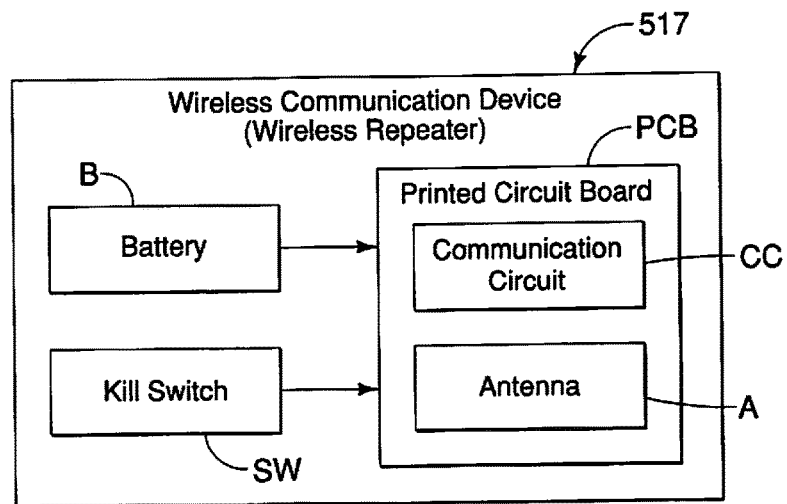

FIG. 36

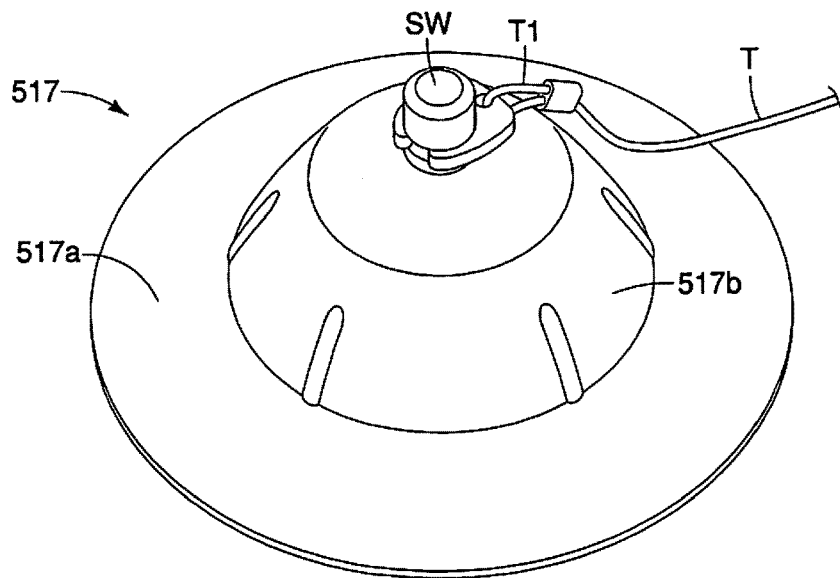

FIG. 37

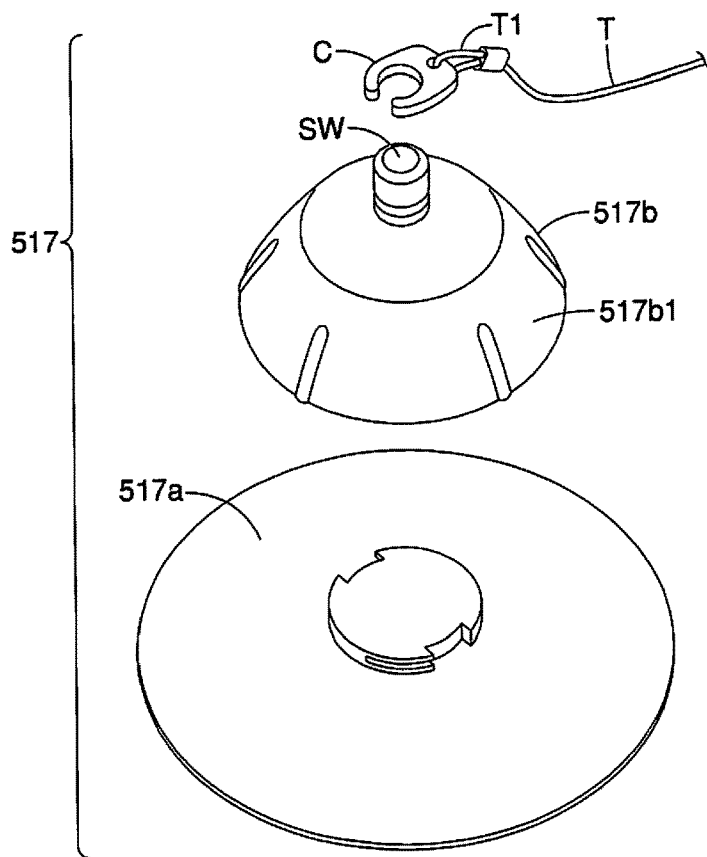

FIG. 38

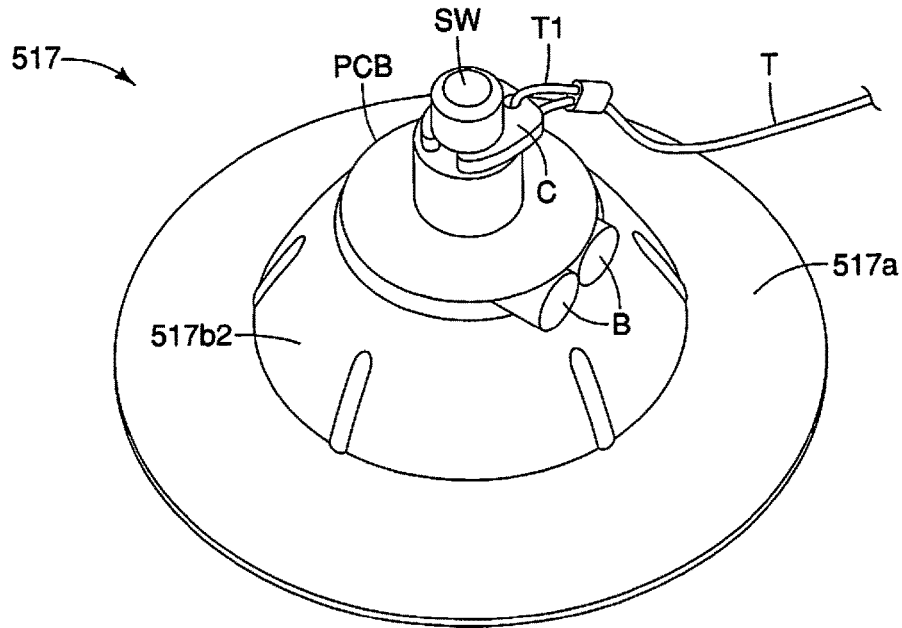

FIG. 39

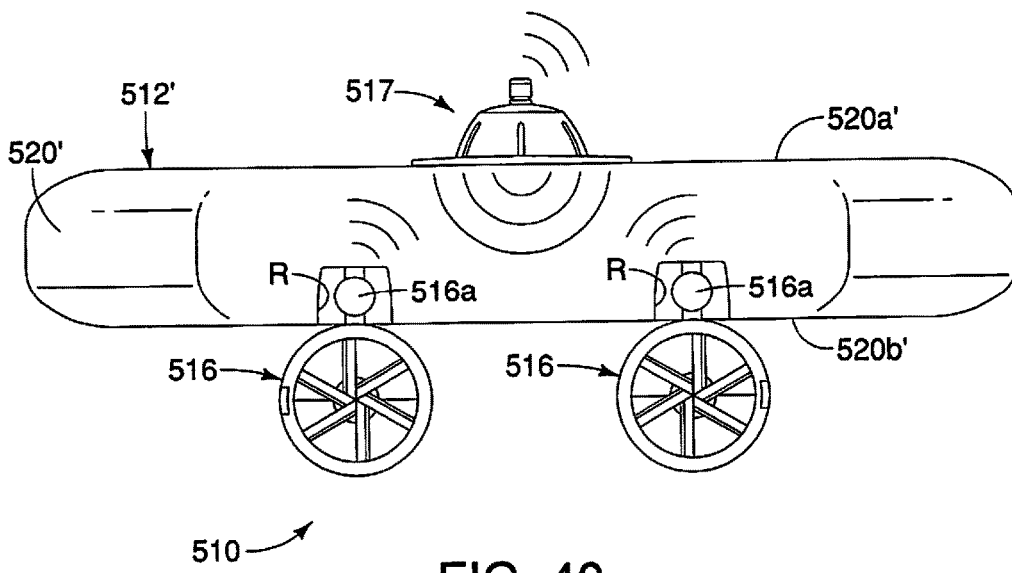

FIG. 40

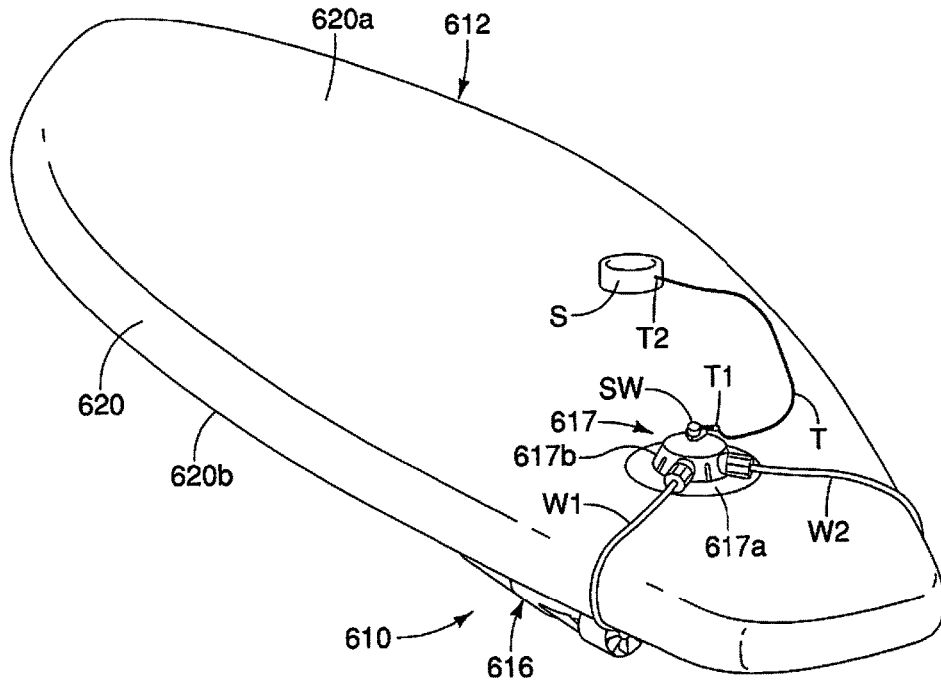

FIG. 41

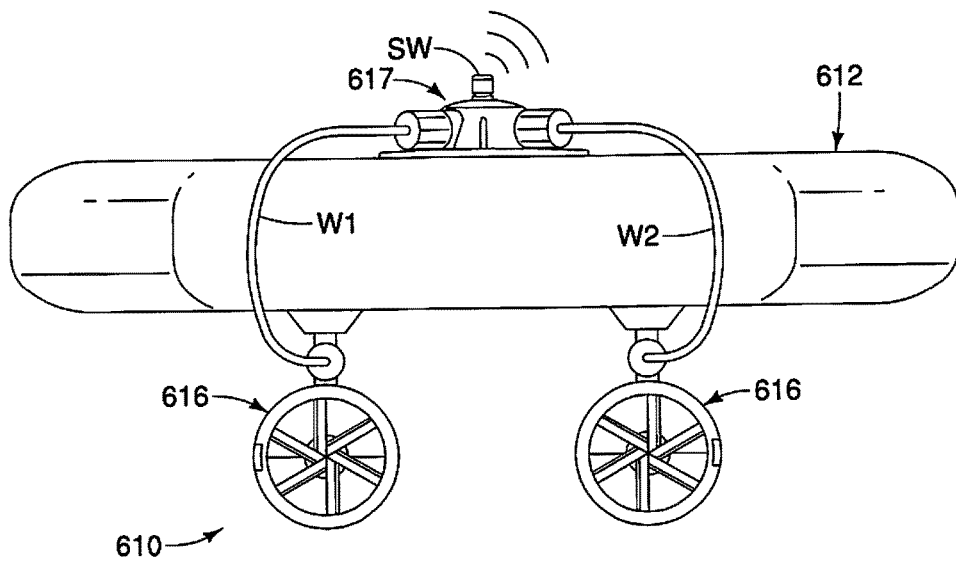

FIG. 42

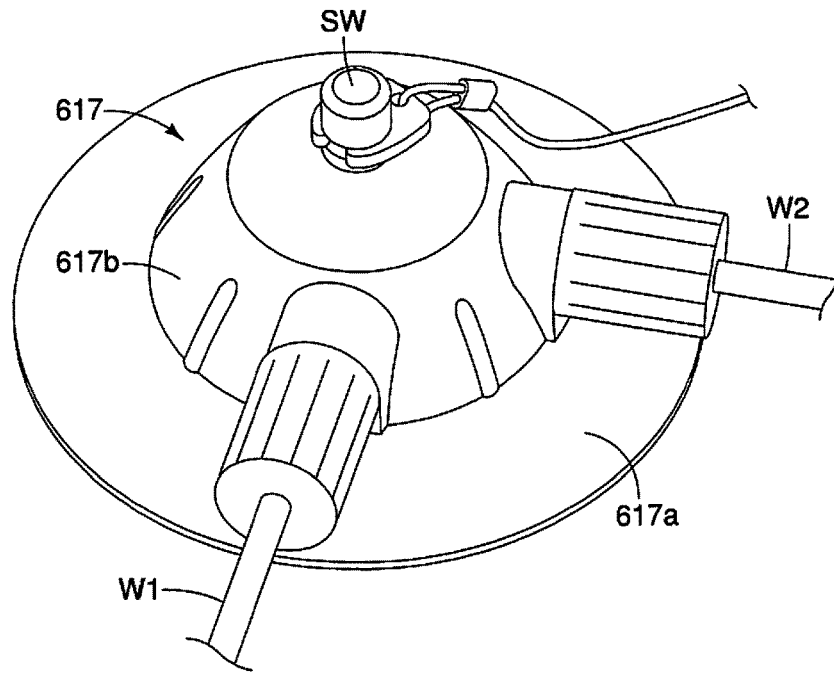

FIG. 43

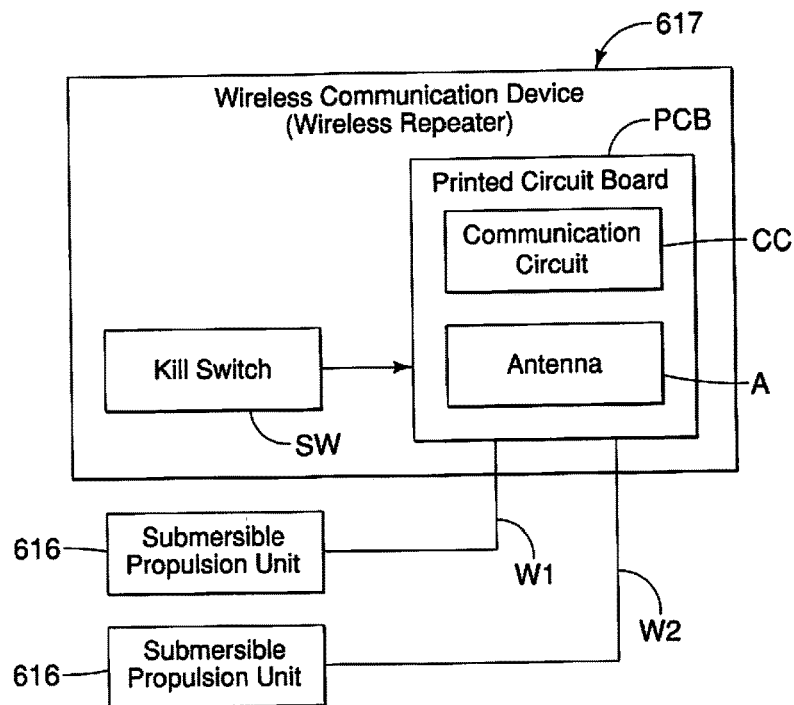

FIG. 44

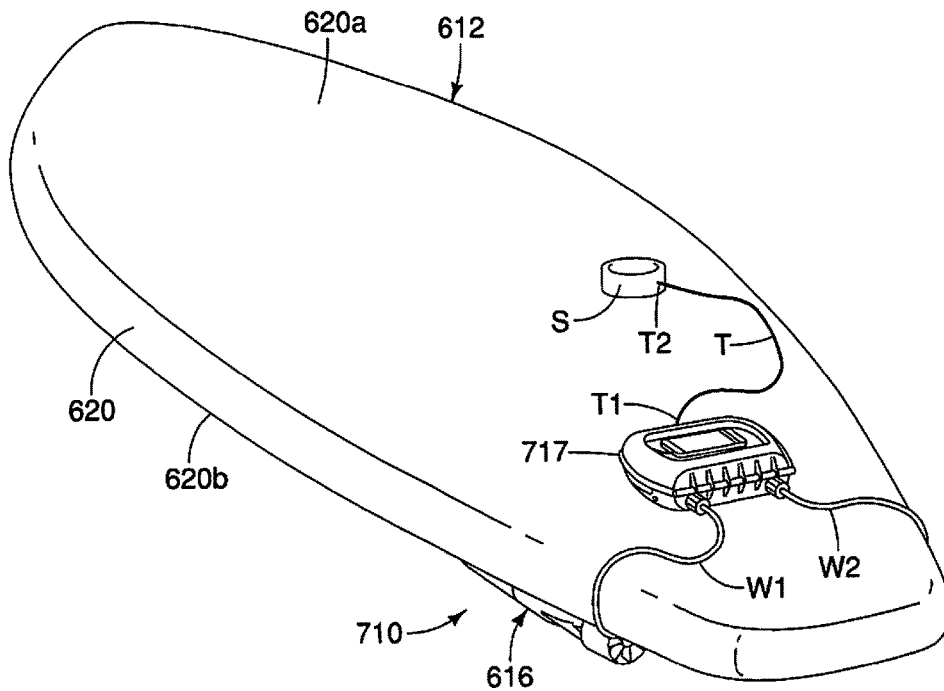

FIG. 45

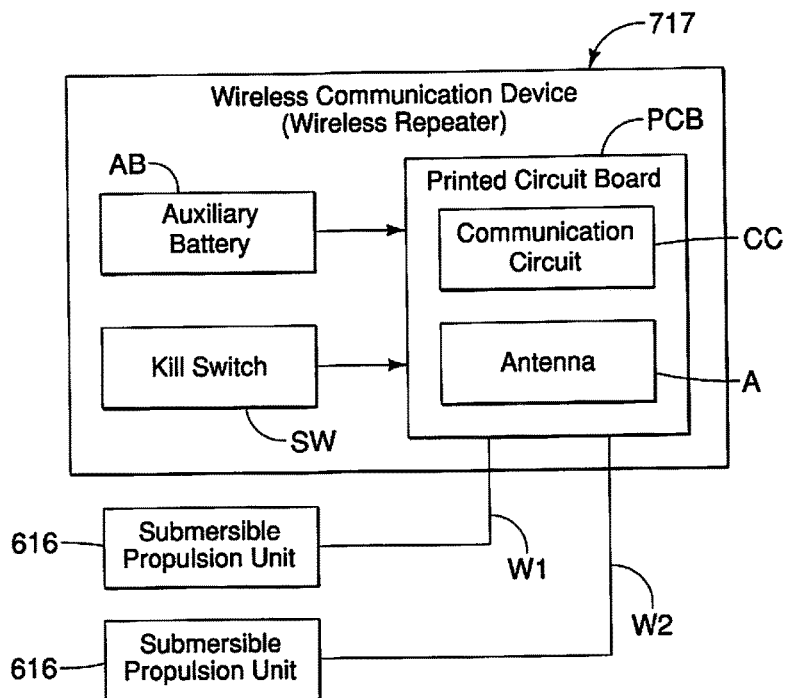

FIG. 46

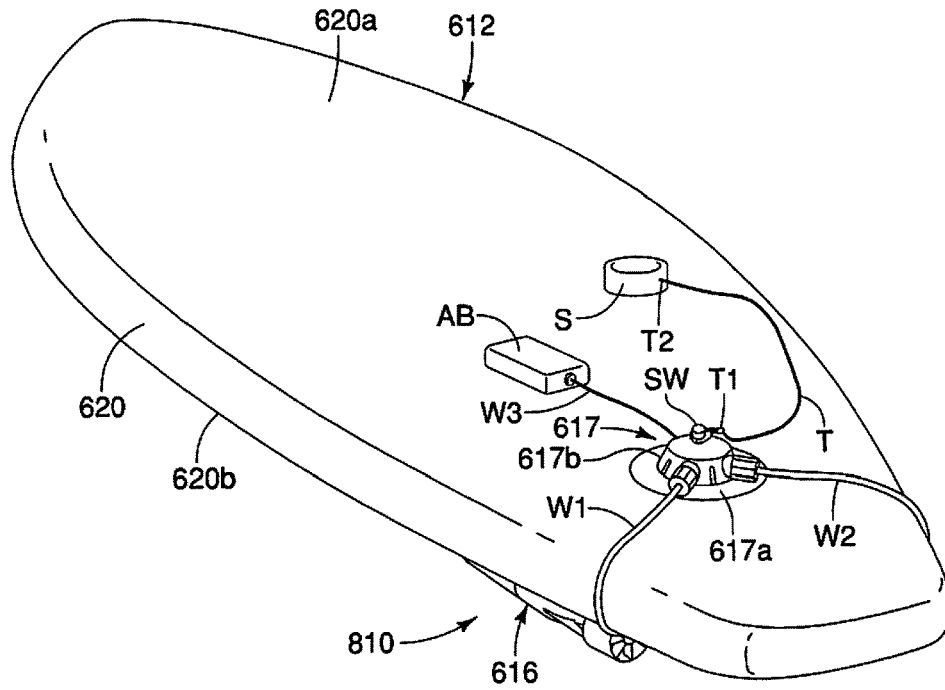

FIG. 47

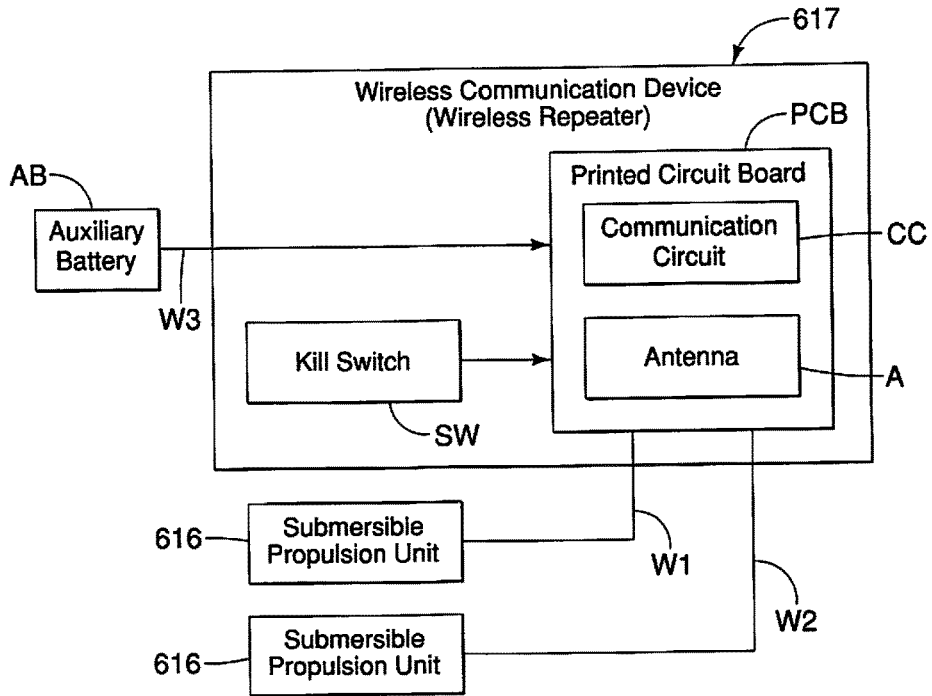

FIG. 48

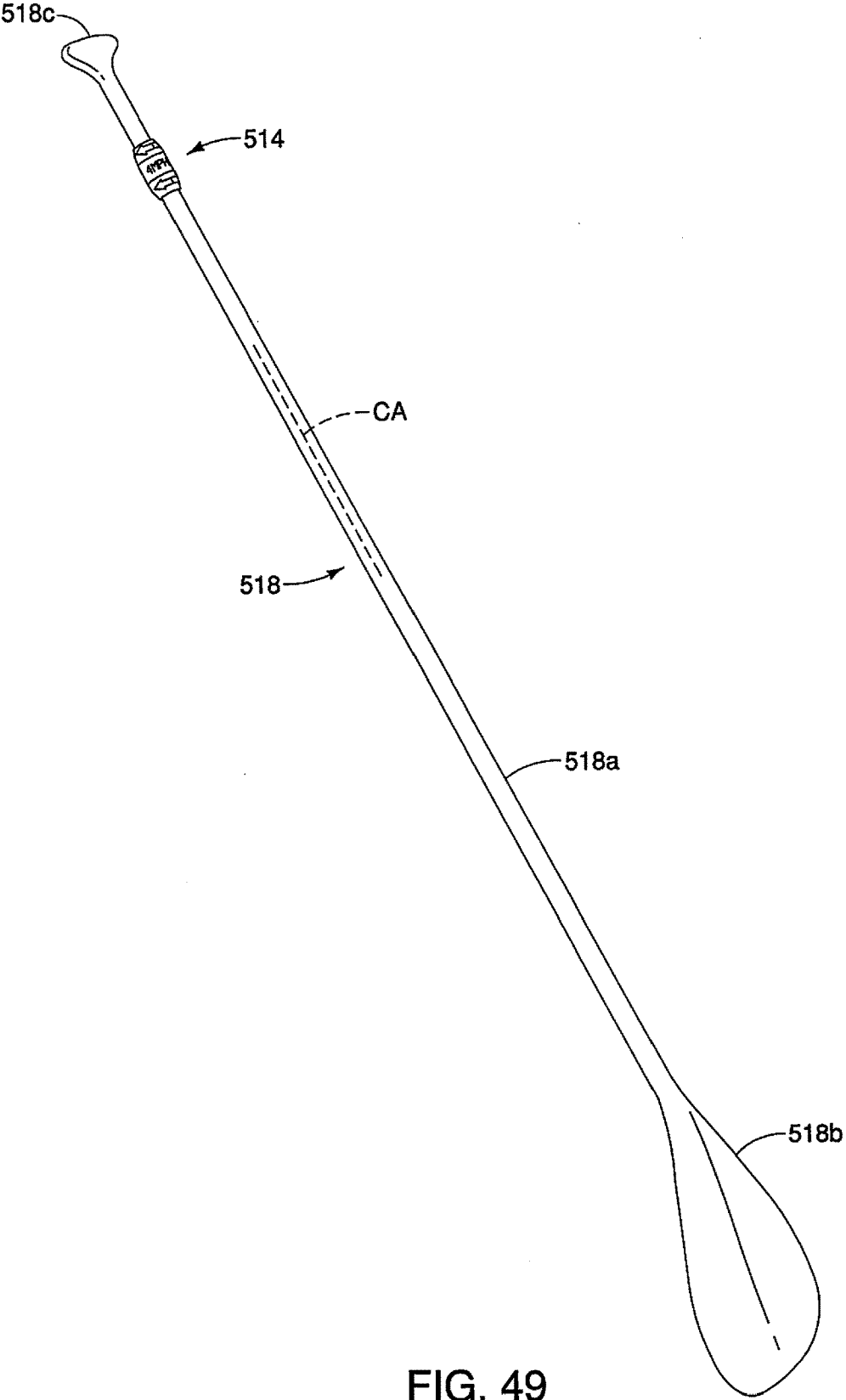
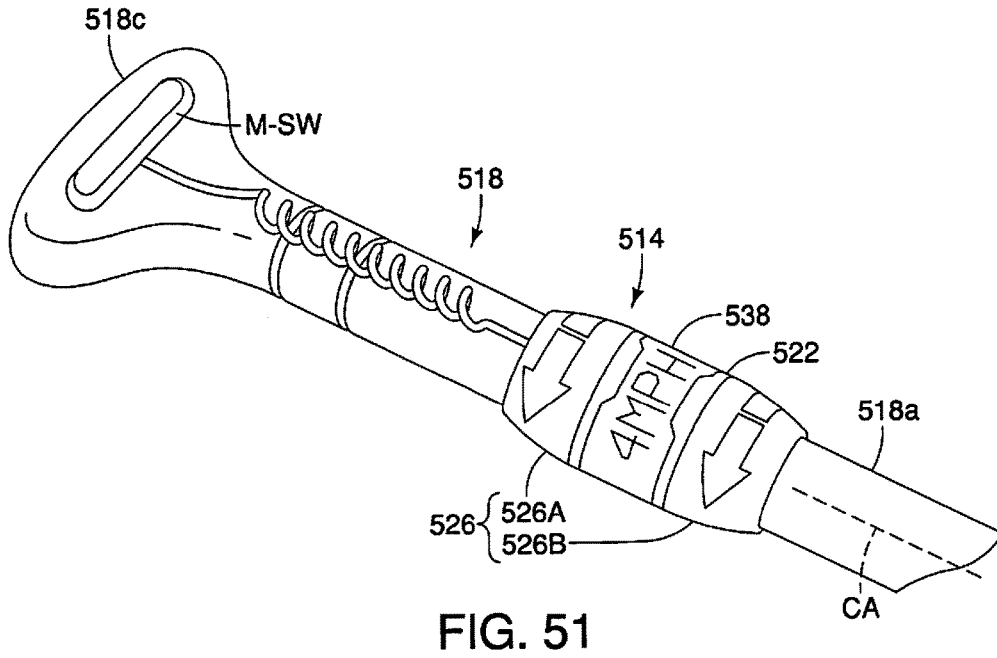
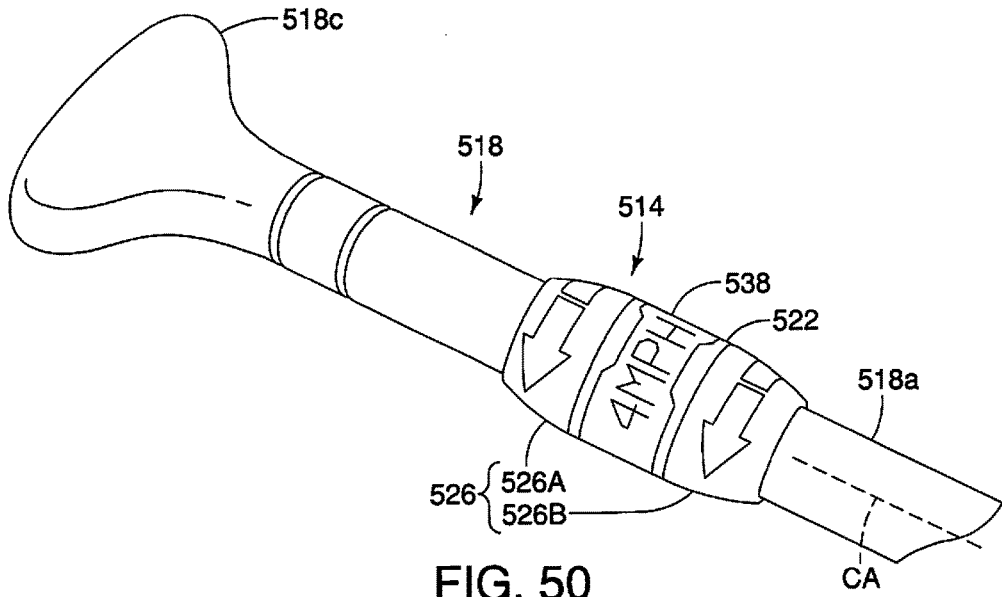

FIG. 49





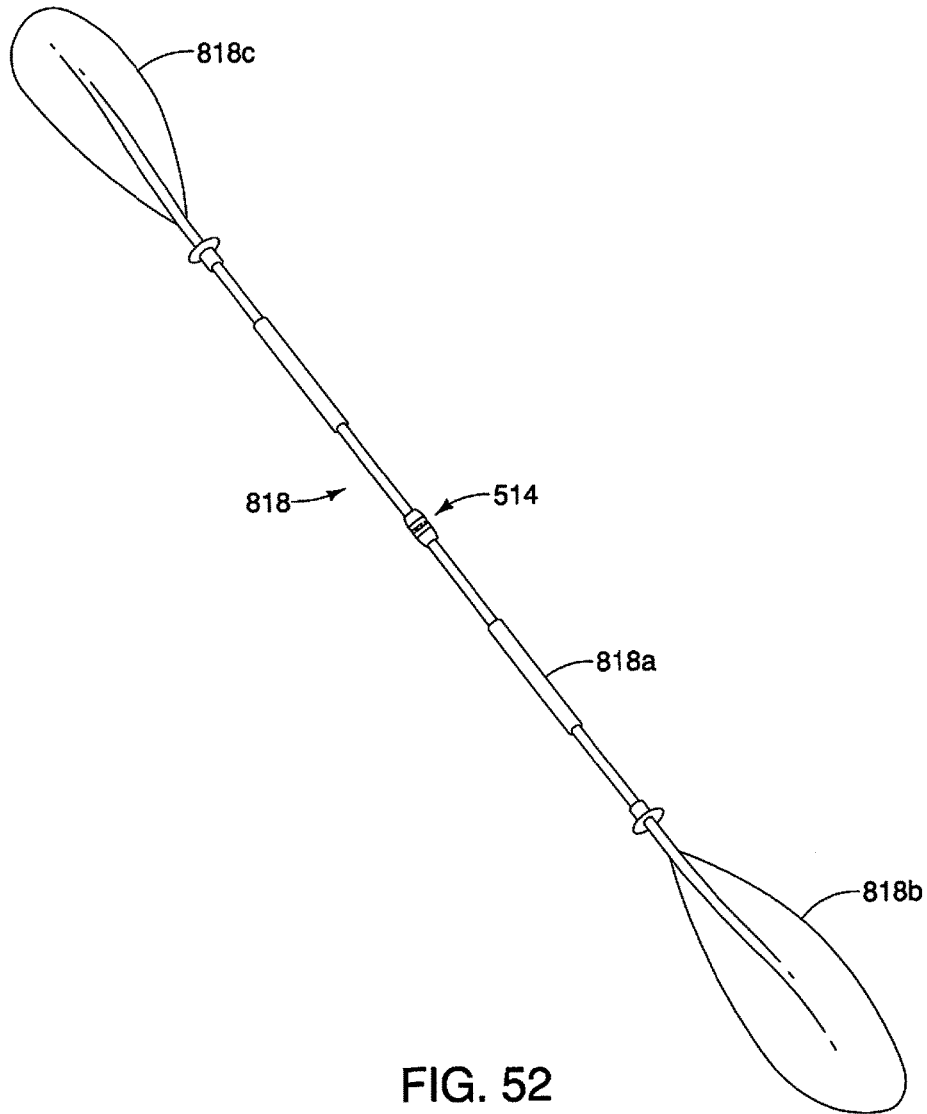

FIG. 52

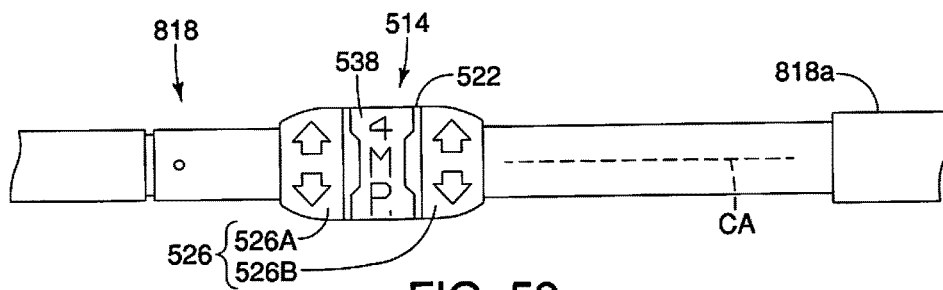

FIG. 53

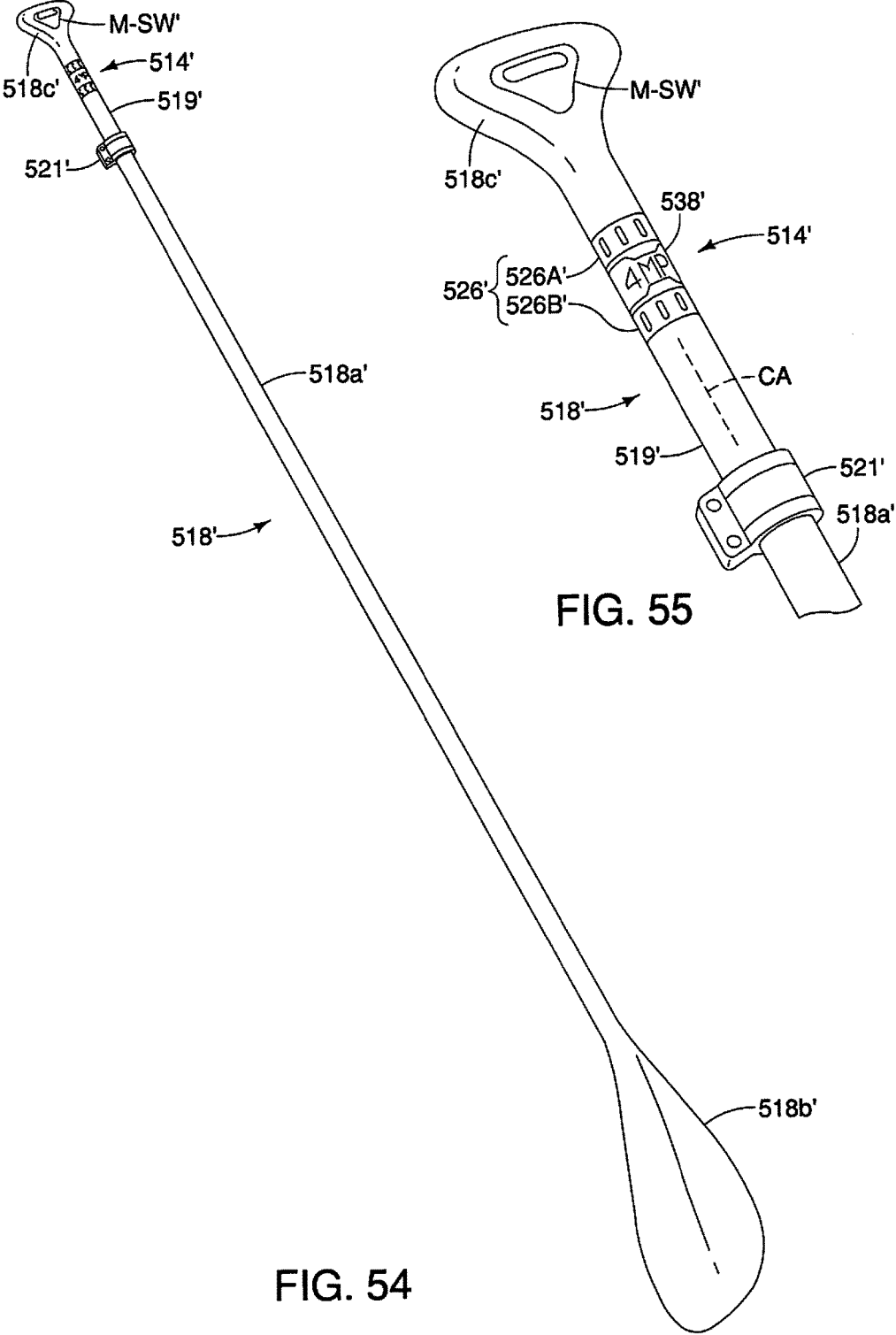

FIG. 54

FIG. 55

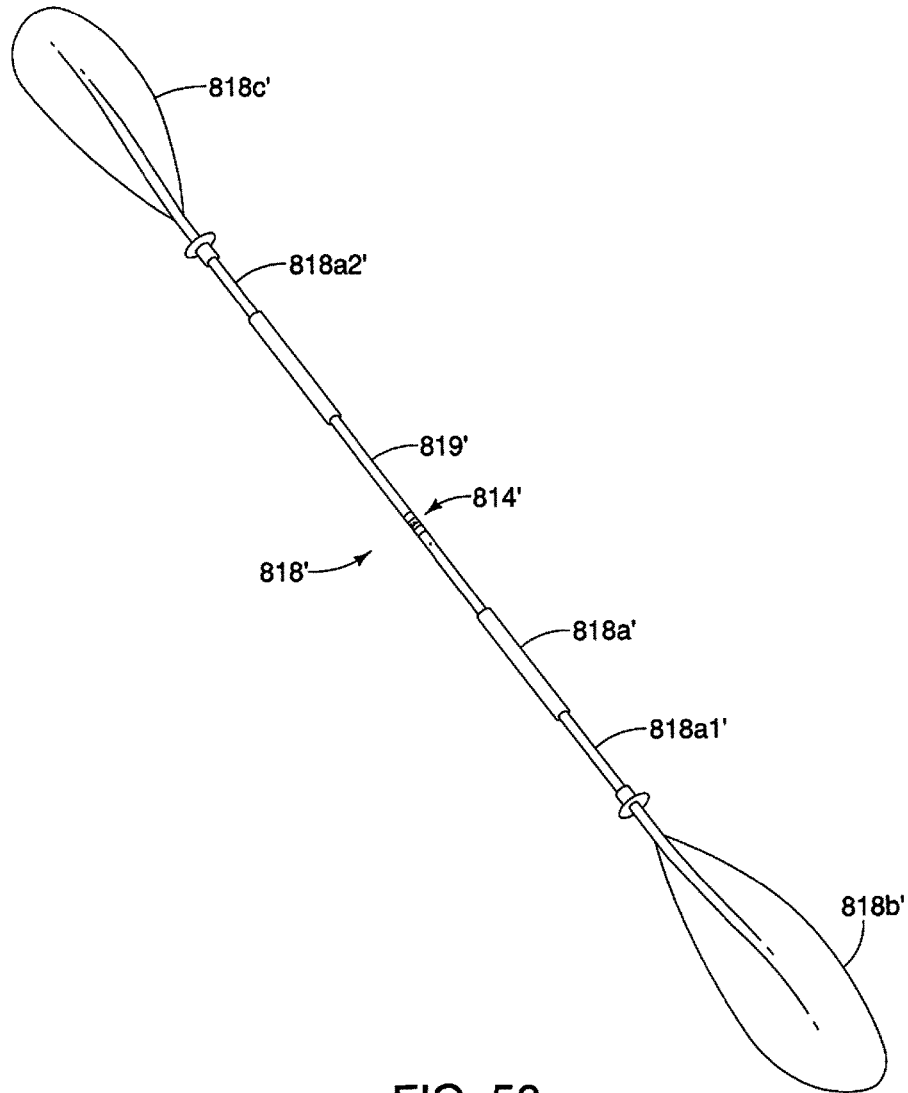

FIG. 56

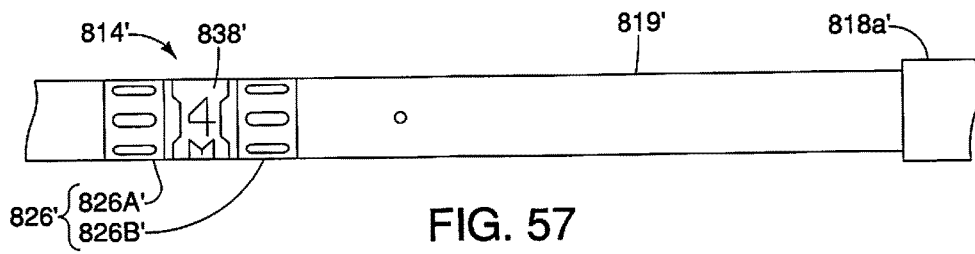

FIG. 57

**AQUATIC VESSEL AND PADDLE****CROSS-REFERENCE TO RELATED APPLICATIONS**

**[0001]** This application is a continuation-in-part application of U.S. patent application Ser. No. 15/383,053 filed on Dec. 19, 2016. The entire disclosure of U.S. patent application Ser. No. 15/383,053 is hereby incorporated herein by reference.

**BACKGROUND****Field of the Invention**

**[0002]** The present invention generally relates to the field of aquatic vessels and paddle used with aquatic vessels.

**Background Information**

**[0003]** Aquatic vessels (e.g., stand up paddle boards, kayaks, canoes, surfboards, boats, submersibles, etc.) are used for many purposes such as for recreation, exercise or transportation. Depending on the purpose of the aquatic vessel, a propulsion device may be provided. In some instances, the aquatic vessel is primarily designed to be used without a propulsion device such as in the cases of stand up paddle boards, kayaks, canoes and surfboards. However, even with these types of aquatic vessel that typically do not have a propulsion device, sometimes situations arise in which it is desirable to have a propulsion device. One example of an aquatic vessel with a propulsion device is disclosed in U.S. Patent Publication No. 2003/0167991 A1, which discloses a motorized surfboard.

**SUMMARY**

**[0004]** In view of the current state of the technology, it has been discovered that a need exists for an aquatic jet propulsion device that is relatively compact and lightweight so as to not interfere with the normal non-motor propelled operation of the aquatic vessel.

**[0005]** Generally, the present disclosure is directed to various features of aquatic vessels having an aquatic jet propulsion device and a paddle that can be used to operate the aquatic jet propulsion device of the aquatic vessel.

**[0006]** In accordance with one aspect of the present disclosure, an aquatic jet propulsion device is provided that basically includes a floating body, a submersible propulsion unit and a communication device. The floating body has an above water level surface and a below water level surface. The submersible propulsion unit is disposed on the floating body beneath the below water level surface of the floating body. The communication device is disposed on the floating body above the above water level surface of the floating body. The communication device is wired to the submersible propulsion unit, and is configured to wirelessly communicate with a control module.

**[0007]** Also, other features, aspects and advantages of the disclosed aquatic jet propulsion devices will become apparent to those skilled in the field of aquatic jet propulsion devices from the following detailed description, which, taken in conjunction with the annexed drawings, discloses several illustrative embodiments of an aquatic jet propulsion device with various features.

**BRIEF DESCRIPTION OF THE DRAWINGS**

**[0008]** Referring now to the attached drawings which form a part of this original disclosure:

**[0009]** FIG. 1 is a rear perspective view of an aquatic vessel (i.e., a stand up paddle board) equipped with an aquatic jet propulsion device in accordance with a first embodiment, in which the aquatic jet propulsion device includes a portable main control module and a pair of submersible propulsion units;

**[0010]** FIG. 2 is a perspective view of the aquatic jet propulsion device illustrated in FIG. 1;

**[0011]** FIG. 3 is a block diagram of the portable main control module of the aquatic jet propulsion device illustrated in FIGS. 1 and 2;

**[0012]** FIG. 4 is a block diagram of one of the submersible propulsion units of the aquatic jet propulsion device illustrated in FIGS. 1 and 2;

**[0013]** FIG. 5 is a side elevational view of one of the submersible propulsion units of the aquatic jet propulsion device illustrated in FIGS. 1 and 2;

**[0014]** FIG. 6 is a top plan view of the submersible propulsion unit illustrated in FIG. 5;

**[0015]** FIG. 7 is a front end elevational view of the submersible propulsion unit illustrated in FIGS. 5 and 6;

**[0016]** FIG. 8 is a rear end elevational view of the submersible propulsion unit illustrated in FIGS. 5 to 7;

**[0017]** FIG. 9 is a perspective view of the motor unit of the submersible propulsion unit illustrated in FIGS. 5 to 8 with the battery unit detached from the motor unit;

**[0018]** FIG. 10 is a perspective view of the battery unit of the submersible propulsion unit illustrated in FIGS. 5 to 8 with the motor unit detached from the battery unit;

**[0019]** FIG. 11 is a longitudinal cross-sectional view of the motor unit and the battery unit of the submersible propulsion unit illustrated in FIGS. 5 to 8;

**[0020]** FIG. 12 is an enlarged longitudinal cross-sectional view of a portion of the motor unit and the battery unit of the submersible propulsion unit illustrated in FIG. 11;

**[0021]** FIG. 13 is a longitudinal cross-sectional view of the motor unit of the submersible propulsion unit illustrated in FIGS. 5 to 8 and several battery units that can be selectively attached to the motor unit;

**[0022]** FIG. 14 is an exploded perspective view of a pair of mounting members used for attaching each of the submersible propulsion units to an aquatic vessel such as the stand up paddle board illustrated in FIG. 1;

**[0023]** FIG. 15 is an assembled perspective view of the mounting members illustrated in FIG. 14 with a portion of the aquatic vessel shown in broken lines;

**[0024]** FIG. 16 is a first portion of a flow chart executed by a main controller of the portable main control module illustrated in FIGS. 1 to 3;

**[0025]** FIG. 17 is a second portion of the flow chart illustrated in FIG. 16, which is executed by a main controller of the portable main control module illustrated in FIGS. 1 to 3;

**[0026]** FIG. 18 is a third portion of the flow chart illustrated in FIGS. 16 and 17, which is executed by a main controller of the portable main control module illustrated in FIGS. 1 to 3;

**[0027]** FIG. 19 is a rear perspective view of an aquatic jet propulsion device in accordance with a first modification in which the portable main control module is connected to the aquatic vessel (i.e., a stand up paddle board) by a tether;

[0028] FIG. 20 is a perspective view of a portable main control module provided with a joint movement input device having a joint attachment and an input member that inputs a control signal upon being flexed in accordance with another modification of the first embodiment;

[0029] FIG. 21 is a rear perspective view of an aquatic vessel (i.e., a stand up paddle board) equipped with an aquatic jet propulsion device, in which the aquatic jet propulsion device includes a portable main control module, a pair of submersible propulsion units and a single sub-two-way communication device shared by the submersible propulsion units in accordance with another illustrated embodiment;

[0030] FIG. 22 is a block diagram of the submersible propulsion units and the sub-two-way communication device of the aquatic jet propulsion device illustrated in FIG. 21;

[0031] FIG. 22 is a perspective view of a portable main control module provided with a joint movement input device having a joint attachment and an input member that inputs a control signal upon being flexed in accordance with another illustrated embodiment;

[0032] FIG. 23 is a rear perspective view of an aquatic vessel (i.e., a stand up paddle board) equipped with an aquatic jet propulsion device, in which the aquatic jet propulsion device includes a portable main control module and a pair of submersible propulsion units in which the portable main control module is attached to the aquatic vessel in accordance with another illustrated embodiment;

[0033] FIG. 24 is a block diagram of the portable main control module for the aquatic jet propulsion device illustrated in FIG. 23;

[0034] FIG. 25 is a rear perspective view of an aquatic vessel (i.e., a kayak) equipped with an aquatic jet propulsion device in accordance with another illustrated embodiment, in which the aquatic jet propulsion device includes a portable main control module and a pair of submersible propulsion units;

[0035] FIG. 26 is a rear end view of the aquatic vessel (i.e., a kayak) illustrated in FIG. 25 in which the V-shaped hull has slanted surfaces with the submersible propulsion units attached to the slanted surfaces of the V-shaped hull;

[0036] FIG. 27 is a block diagram of the portable main control module for the aquatic jet propulsion device illustrated in FIGS. 25 and 26;

[0037] FIG. 28 is a side perspective view of an aquatic vessel (i.e., an inflatable pontoon boat) equipped with an aquatic jet propulsion device in accordance with yet another illustrated embodiment, in which the aquatic jet propulsion device includes a portable main control module and a pair of submersible propulsion units;

[0038] FIG. 29 is a perspective view of a diver attached aquatic jet propulsion device in accordance with a yet still another illustrated embodiment, in which the aquatic jet propulsion device includes a portable main control module and two submersible propulsion units that are the diver's thighs;

[0039] FIG. 30 is a longitudinal cross-sectional view of a submersible propulsion unit in accordance with another illustrated embodiment in which the motor unit and the battery unit are integrated into a single housing;

[0040] FIG. 31 is a longitudinal cross-sectional view of the submersible propulsion unit illustrated in FIG. 30 with its end cap removed and replaced with an additional battery;

[0041] FIG. 32 is a rear perspective view of an aquatic vessel (i.e., a stand up paddle board) equipped with an aquatic jet propulsion device in accordance with another illustrated embodiment, in which the aquatic jet propulsion device includes a control module on a stand up paddle, a wireless communication device mounted on a top surface of the stand up paddle board and a pair of submersible propulsion units mounted on a bottom surface of the stand up paddle board that wirelessly communicate with the communication device which also wirelessly communicate with the control module on the stand up paddle;

[0042] FIG. 33 is a rear perspective view of the aquatic vessel and the aquatic jet propulsion device illustrated in FIG. 32;

[0043] FIG. 34 is a rear end elevational view of the aquatic vessel and the aquatic jet propulsion device illustrated in FIGS. 32 and 33;

[0044] FIG. 35 is a block diagram of the control module of the aquatic jet propulsion device illustrated in FIG. 32;

[0045] FIG. 36 is a block diagram of the wireless communication device of the aquatic jet propulsion device illustrated in FIGS. 32 to 34;

[0046] FIG. 37 is a perspective view of the communication device that is shared by each of the submersible propulsion units of the aquatic jet propulsion device illustrated in FIGS. 32 to 34;

[0047] FIG. 38 is a partially exploded perspective view of the communication device illustrated in FIGS. 36 and 37;

[0048] FIG. 39 is a perspective view of the communication device illustrated in FIGS. 37 and 38 but with a cover removed;

[0049] FIG. 40 is a rear end elevational view of a modified aquatic vessel in which the submersible propulsion units of the aquatic jet propulsion device have external antennas recessed into the stand up paddle board;

[0050] FIG. 41 is a rear perspective view of an aquatic vessel (i.e., a stand up paddle board) equipped with an aquatic jet propulsion device in accordance with another illustrated embodiment, in which the aquatic jet propulsion device includes a control module (not shown), a communication device mounted on a top surface of the stand up paddle board and a pair of submersible propulsion units mounted on a bottom surface of the stand up paddle board that are wired to communicate with the communication device which wirelessly communicate with the control module (not shown);

[0051] FIG. 42 is a rear end elevational view of the aquatic vessel and the aquatic jet propulsion device illustrated in FIG. 41;

[0052] FIG. 43 is a perspective view of the communication device that is shared by each of the submersible propulsion units of the aquatic jet propulsion device illustrated in FIGS. 41 and 42;

[0053] FIG. 44 is a block diagram of the wireless communication device and the submersible propulsion units of the aquatic jet propulsion device illustrated in FIGS. 41 to 43;

[0054] FIG. 45 is a rear perspective view of an aquatic vessel (i.e., a stand up paddle board) equipped with an aquatic jet propulsion device in accordance with another illustrated embodiment, in which the aquatic jet propulsion device includes a control module (not shown), an auxiliary battery pack-communication device mounted on a top surface of the stand up paddle board and a pair of submersible

propulsion units mounted on a bottom surface of the stand up paddle board that are wired to communicate with the auxiliary battery pack-communication device which wirelessly communicate with the control module (not shown);

[0055] FIG. 46 is a block diagram of the wireless communication device and the submersible propulsion units of the aquatic jet propulsion device illustrated in FIG. 45;

[0056] FIG. 47 is a rear perspective view of an aquatic vessel (i.e., a stand up paddle board) equipped with an aquatic jet propulsion device in accordance with another illustrated embodiment, in which the aquatic jet propulsion device includes a control module (not shown), a communication device mounted on a top surface of the stand up paddle board, an auxiliary battery pack externally coupled to the communication device and a pair of submersible propulsion units mounted on a bottom surface of the stand up paddle board that are wired to communicate with the communication device which wirelessly communicate with the control module (not shown);

[0057] FIG. 48 is a block diagram of the wireless communication device, the auxiliary battery pack and the submersible propulsion units of the aquatic jet propulsion device illustrated in FIG. 47;

[0058] FIG. 49 is a perspective view of the stand up paddle having the control module illustrated in FIG. 32;

[0059] FIG. 50 is a partial perspective view of a part of the stand up paddle having the control module illustrated in FIG. 49;

[0060] FIG. 51 is a partial perspective view of the part of the stand up paddle illustrated in FIG. 50 but with a pressure switch added;

[0061] FIG. 52 is a perspective view of a kayak paddle having a control module for use with the aquatic jet propulsion device installed on an aquatic vessel (i.e., a kayak) such as shown in FIG. 25;

[0062] FIG. 53 is a partial elevational view of a part of the kayak paddle having the control module illustrated in FIG. 52;

[0063] FIG. 54 is a perspective view of another stand up paddle having a control module for use with the aquatic jet propulsion device installed on an aquatic vessel (i.e., a stand up paddle board) such as shown in FIGS. 1, 32, 41 and 45;

[0064] FIG. 55 is a partial perspective view of a part of the stand up paddle having the control module illustrated in FIG. 54;

[0065] FIG. 56 is a perspective view of another kayak paddle having a control module for use with the aquatic jet propulsion device installed on an aquatic vessel (i.e., a kayak) such as shown in FIG. 25; and

[0066] FIG. 57 is a partial elevational view of a part of the kayak paddle having the control module illustrated in FIG. 56.

[0067] It should be noted that these figures are intended to illustrate the general characteristics of methods, structure and/or materials utilized in certain illustrative embodiments and to supplement the written description provided below. These drawings are not, however, to scale and may not precisely reflect the precise structural or performance characteristics of any given embodiment, and should not be interpreted as defining or limiting the range of values or properties encompassed by illustrative embodiments. The use of similar or identical reference numbers in the various drawings is intended to indicate the presence of a similar or identical element or feature.

#### DETAILED DESCRIPTION OF EMBODIMENTS

[0068] Selected embodiments will now be explained with reference to the drawings. It will be apparent to those skilled in the field of aquatic jet propulsion devices from this disclosure that the following descriptions of the embodiments are provided for illustration only and not for the purpose of limiting the invention as defined by the appended claims and their equivalents. Like reference numerals in the drawings denote like similar or identical elements or features, and thus the descriptions of the similar or identical elements or features may be omitted in later embodiments.

[0069] Referring initially to FIG. 1, an aquatic jet propulsion device 10 is illustrated in accordance with a first embodiment. As seen in FIG. 1, the aquatic jet propulsion device 10 is installed on a stand up paddle (SUP) board 12, which is an example of an aquatic vessel. However, it will be apparent to those skilled in the field of aquatic jet propulsion devices from this disclosure that the aquatic jet propulsion device 10 can be used with other types of aquatic vessels, and thus are not limited to any particular aquatic vessels. An aquatic vessel as used herein is a structure that a reasonable observer looking at the structure's physical characteristics and activities would consider it designed to a practical degree for carrying people or things over water or underwater. For example, an aquatic vessel includes personal floatation devices and scuba gear that that is designed to carrying people or things over water or underwater. Accordingly, the stand up paddle (SUP) board 12 will hereinafter be simply referred to the aquatic vessel 12.

[0070] Basically, as seen in FIGS. 1 and 2, in the first embodiment, the aquatic jet propulsion device 10 comprises a portable main control module 14 and a plurality of submersible propulsion units 16A and 16B. Here, in the first embodiment, the aquatic jet propulsion device 10 includes only two of the submersible propulsion units 16A and 16B. However, it will be apparent to those skilled in the field of aquatic jet propulsion devices from this disclosure that the aquatic jet propulsion device 10 can be configured with only a single one of the submersible propulsion units 16A and 16B, or more than two of the submersible propulsion units 16A and 16B, as needed and/or desired for the particular device.

[0071] Referring again to FIG. 1, in the first embodiment, the portable main control module 14 is configured as a wearable device that is configured to be worn on the wrist of the user of the aquatic vessel 12. However, the portable main control module 14 is not limited to being configured to be worn on the wrist of the user of the aquatic vessel 12. For example, the portable main control module 14 can be configured to be mounted on a paddle 18 of the aquatic vessel 12 or some other area of the user's body.

[0072] As seen in FIG. 1, the aquatic vessel 12 further comprises a floating body 20 having an above water level surface 20a and a below water level surface 20b. The submersible propulsion units 16A and 16B are attached to the below water level surface 20b. As explained hereinafter, the submersible propulsion units 16A and 16B are preferably configured to be detachable and reinstallable to the below water level surface 20b without damaging the aquatic vessel 12. Also, preferable, in the first embodiment, the aquatic jet propulsion device 10 is configured as an aftermarket add-on kit that can be attached to existing aquatic vessels. Of course, if needed and/or desired, the aquatic jet propulsion device 10 can be an integrated part of an aquatic vessel.

[0073] As illustrated in FIG. 2, the portable main control module 14 is configured to carry out two-way wireless communications with each of the submersible propulsion units 16A and 16B. However, it will be apparent to those skilled in the field of aquatic jet propulsion devices from this disclosure that the portable main control module 14 can be interconnected to the submersible propulsion units 16A and 16B by wires for carrying out two-way communications therebetween if needed and/or desired. Here, in the first embodiment, the aquatic jet propulsion device 10 uses Bluetooth® communications to wirelessly send signals between the portable main control module 14 and each of the submersible propulsion units 16A and 16B. However, it will be apparent to those skilled in the field of aquatic jet propulsion devices from this disclosure that the two-way wireless communications can be carried out using other wireless technology as needed and/or desired.

[0074] Referring now to FIGS. 2 and 3, in the first embodiment, the portable main control module 14 will now be discussed in more detail. As seen in FIG. 2, the portable main control module 14 includes a control module housing 22 and a mounting strap 24. The control module housing 22 is a watertight housing that houses the various components that are diagrammatically illustrated in FIG. 3. The mounting strap 24 is molded onto the control module housing 22. The mounting strap 24 is an elastic strap that is designed to be placed on the user's wrist, or can be dimensioned to be installed on the paddle 18 or other parts of the aquatic vessel 12. However, it will be apparent to those skilled in the field of aquatic jet propulsion devices from this disclosure that the control module housing 22 can be supported on the user or other parts of an aquatic vessel as needed and/or desired.

[0075] As seen in FIGS. 2 and 3, the portable main control module 14 includes a user input interface 26. Here, the user input interface 26 includes push buttons that are exposed through the control module housing 22. Alternatively, the push buttons of the user input interface 26 can be replaced with any combination of input devices that include, but not limited to, push buttons, knobs, wheels, touch screens, etc. In the first embodiment, the user input interface 26 includes a main on-off switch 30, a forward input 31 (i.e., a first speed control input), a rearward input 32 (i.e., a second speed control input), a left turn input 33, a right turn input 34, a battery condition indicator 35 and a leak indicator 36. The user input interface 26 can include other types of inputs as needed and/or desired. For example, the user input interface 26 can be provided with a separate pairing switch that could be provided on a rear face of the control module housing 22.

[0076] The main on-off switch 30 is a button-type switch that turns on and off the various components of the portable main control module 14 in a conventional manner. The main on-off switch 30 constitutes an activation switch configured to activate the portable main control module 14. Here, the main on-off switch 30 is on a side edge of the control module housing 22 that is separate from the other inputs for easy operation and for avoiding accident operation. The forward input 31 and the rearward input 32 are button-type switches that are located on a front face of the control module housing 22. The forward input 31 and the rearward input 32 are used to simultaneously control the output speeds and the thrust directions of both of the submersible propulsion units 16A and 16B. For example, each of the forward input 31 and the rearward input 32 can be pressed to switch sequentially between four speeds (e.g., a stop setting, an eco or low speed

setting, a standard or medium speed setting, and a high speed setting). The left turn input 33 and the right turn input 34 are also button-type switches that are located on a front face of the control module housing 22. By pressing one of the left turn input 33 and the right turn input 34, the thrust direction on one of the submersible propulsion units 16A and 16B is reversed with respect to the other of the submersible propulsion units 16A and 16B to perform a turn in the desired direction.

[0077] The battery condition indicator 35 and the leak indicator 36 are light indicators such as LED. The case of the battery condition indicator 35 can be configured to emit different colors of light depending on the battery status of the submersible propulsion units 16A and 16B. For example, the battery condition indicator 35 can be configured to emit green light when the battery capacity of both of the submersible propulsion units 16A and 16B is above a first prescribed battery capacity threshold. The battery condition indicator 35 can be configured to emit yellow or amber light when the battery capacity of at least one of the submersible propulsion units 16A and 16B is below the first prescribed battery capacity threshold. The battery condition indicator 35 can be configured to emit red light when the battery capacity of at least one of the submersible propulsion units 16A and 16B is below a second battery capacity threshold that corresponds to a preset minimum operating battery capacity. On the other hand, the leak indicator 36 can normally be unlit, and then configured to emit red light when a water leak is detected in one of the submersible propulsion units 16A and 16B.

[0078] As seen in FIG. 3, the portable main control module 14 further includes a main controller 40 and a main two-way communication device 42. Basically, the main controller 40 receives user inputs via the user input interface 26 and outputs control signals to the two-way communication device 42 that in turn transmits the control signals to the submersible propulsion units 16A and 16B. In addition, the main controller 40 receives propulsion unit data from each of the submersible propulsion units 16A and 16B via the two-way communication device 42. In response to the user inputs via the user input interface 26 and the propulsion unit data from each of the submersible propulsion units 16A and 16B, the main controller 40 controls the operation of the submersible propulsion units 16A and 16B in a manner intended by that user. Also, the main controller 40 preferably outputs propulsion unit status data to the user input interface 26 for informing the user of the condition of the submersible propulsion units 16A and 16B such as outputting battery condition data to the battery condition indicator 35 and a water leak detection to the leak indicator 36.

[0079] The main controller 40 basically has at least one processor with at least one control program (e.g., the control program diagrammatically illustrated in FIGS. 14 to 16) that controls the operations of the submersible propulsion units 16A and 16B as discussed below. More preferably, the main controller 40 is a microcomputer that in addition to the at least one processor further includes other conventional components such as an input interface circuit, an output interface circuit, and storage devices, such as a ROM (Read Only Memory) device and a RAM (Random Access Memory) device, flash memory, etc. The storage devices store processing results, operation and condition data received from



the submersible propulsion units 16A and 16B and control programs that are run by the at least one processor of the main controller 40.

[0080] For example, the internal RAM of the main controller 40 stores statuses of operational flags and various input operations from the user input interface 26, and condition data received from the submersible propulsion units 16A and 16B. The internal ROM of the main controller 40 stores the information and programs for various operations. It will be apparent to those skilled in the field of aquatic jet propulsion devices from this disclosure that the precise structure and algorithms for the main controller 40 can be any combination of hardware and software that will carry out the functions of the aquatic jet propulsion device 10 as described herein.

[0081] In the first embodiment, the main two-way communication device 42 is a main two-way wireless communication device. For example, the main two-way communication device 42 can be a Bluetooth® radio transceiver that includes both transmitter and receiver functions and that has an integrated antenna. One example of Bluetooth® radio transceiver is an Ericsson PBA 313, 2.4-2.5 GHz Bluetooth® radio transceiver for Bluetooth communication links. Other suitable wireless transceivers and/or wireless personal area networks are contemplated. For example, for fresh water use of the aquatic jet propulsion device 10, an Atmel AT86RF231, 2.4 GHz transceiver utilizing AES encryption and DSS spread spectrum technology supporting 16 channels and the IEEE 802.15.4 communication protocol. In the case of saltwater, the aquatic jet propulsion device 10 preferably uses communication devices that transmits 915 MHz signals. Moreover, the transmitter and the receiver can be separate circuits in the main two-way communication device 42. Thus, it will be noted that the term “two-way communication device” as used herein includes a transceiver, a transmitter-receiver (the transmitter and the receiver are separate circuits), or a radio, and contemplates any device or devices, separate or combined, capable of transmitting and receiving signals, including control signals, command signals or other signals related to some function of the component being controlled. Also, the term “two-way communication device” as used herein includes both wirelessly communication and wired communication unless otherwise specified.

[0082] As seen in FIG. 3, the portable main control module 14 further includes a power source or battery 44 that supplies electrical energy to the components of the portable main control module 14. The battery 44 can be one or more coin type batteries, such as lithium coin cell batteries or similar batteries. The battery 44 can be either a rechargeable battery or a disposable battery. Moreover, the battery 44 can be substituted with other suitable power sources that can supply electrical energy to the components of the portable main control module 14.

[0083] Referring now to FIGS. 2 and 4 to 11, the submersible propulsion units 16A and 16B will now be discussed in more detail. The submersible propulsion units 16A and 16B are identical. Thus, the parts of the submersible propulsion units 16A and 16B will be given the same reference symbols for the sake of brevity. Of course, the submersible propulsion units 16A and 16B can be different as needed and/or desired for an application.

[0084] As seen in FIGS. 2 and 5 to 9, each of the submersible propulsion units 16A and 16B basically

includes a motor unit 46 and a battery unit 48. In each of the submersible propulsion units 16A and 16B, the motor unit 46 has a motor housing 50 and the battery unit 48 has a battery housing 52. Each of the motor housings 50 and each of the battery housings 52 for the submersible propulsion units 16A and 16B are individually watertight. The motor housing 50 and the battery housing 52 are preferably made of a lightweight non-metallic material and/or corrosion resistant alloys such as aluminum, stainless steel, etc.

[0085] Preferably, the battery housing 52 is detachably and reattachably attached to the motor housing 50. Here, in the first embodiment, the battery housing 52 is friction-fitted onto the motor housing 50. In this way, the battery unit 48 is detachable from and reinstallable to the motor unit 46 without damaging either the motor unit 46 and the battery unit 48 as in the first embodiment. In this way, the battery unit 48 can be separated from the motor unit 46 and placed on a battery charger (not shown), and then, the battery unit 48 can be reattached to the motor unit 46 after being recharged. Alternatively, if the battery unit 48 is provided with a pluggable power inlet, then the motor unit 46 and the battery unit 48 can be an integrated unit that is non-separable.

[0086] In the first embodiment, the motor housing 50 includes an annular connection flange or collar 54 at one end and a propeller shroud 56 at the other end. As seen in FIGS. 11 and 12, the annular connection collar 54 has a pair of outer seals 58 disposed on an outer peripheral surface of the annular connection collar 54 and an inner seal 60 disposed on an inner peripheral surface of the annular connection collar 54. The seals 58 and 60 are resilient, elastomeric O-rings that contact the battery housing 52 to create a watertight seal at a connection interface of the motor housing 50 and the battery housing 52. The seals 58 also aid in retaining the motor housing 50 and the battery housing 52 together.

[0087] As seen in FIGS. 11 and 12, the battery housing 52 has an annular connection collar 62 that is configured to mate with the annular connection collar 54 of the motor housing 50. In particular, the annular connection collar 62 is dimensioned to be slightly larger than the outer diameter of the annular connection collar 54 of the motor housing 50. When the annular connection collar 62 of the battery housing 52 is inserted onto the annular connection collar 54 of the motor housing 50, the seals 58 and 60 are compressed to form a watertight seal at a connection interface of the motor housing 50 and the battery housing 52.

[0088] As seen in FIG. 4, each of the submersible propulsion units 16A and 16B basically includes a motor 64, a battery 66 and a motor controller 68. In the first embodiment, each of the submersible propulsion units 16A and 16B further includes a sub-two-way communication device 70. Here, the motor housing 50 contains the motor 64, the motor controller 68 and the sub-two-way communication device 70, while the battery housing 52 includes the battery 66.

[0089] Also, preferably, in the first embodiment, each of the submersible propulsion units 16A and 16B further includes a pair of water leak detectors 72 and 74. The water leak detector 72 is provided inside of the motor housing 50 to detect water entering the motor housing 50, while the water leak detector 74 is provided inside of the battery housing 52 to detect water entering the battery housing 52. The main controller 40 is programmed to stop both of the motors 64 of the first and second submersible propulsion

units 16A and 16B upon receiving a leak detection signal from one of the water leak detectors 72 and 74.

[0090] Also, the motor unit 46 of each of the submersible propulsion units 16A and 16B further includes an on-off switch 76 and a fuse 78. The on-off switch 76 is electrically connected between the battery 66 and the motor controller 68 for selectively turning the motor 64, the motor controller 68 and the sub-two-way communication device 70 on and off. The fuse 78 is disposed in the electrical circuit between the motor 64 and the battery 66. The fuse 78 is configured to disrupt the electrical circuit between the motor 64 and the battery 66 in the event of an overcurrent or overvoltage.

[0091] In the first embodiment, the motor unit 46 of each of the submersible propulsion units 16A and 16B further includes a motor speed detector 79 that is electrical connected to the motor controller 68. The motor speed detector 79 is configured and arranged to detect the rotational speed (rpms) of the motor 64 and provide a current actual rotational speed (rpms) of the motor 64 to the motor controller 68. The motor speed detector 79 can be any conventional motor speed detector that is known or developed in the future. For example, the motor speed detector 79 can be an optical motor speed detector that commonly includes a light emitting diode that provides the illumination, and a phototransistor that senses the presence or absence of that illumination. Alternatively, the motor speed detector 79 can be a magnetic motor speed detector that commonly includes a magnetic that produces a magnetic field and a magnetic encoder that senses the presence or absence of that magnetic field. However, the rotational speed of the motor 64 can be calculated based on the voltage of the motor 64 if needed and/or desired.

[0092] Optionally, the battery unit 48 each of the submersible propulsion units 16A and 16B further includes a battery controller 80 that monitors the battery condition of the battery 66. The battery controller 80 provides battery condition data of the battery 66 to the motor controller 68 and a battery charger (not shown). The battery controller 80 basically has at least one processor with at least one battery monitoring program. More preferably, the battery controller 80 is a microcomputer that in addition to the at least one processor further includes other conventional components such as an input interface circuit, an output interface circuit, and storage devices, such as a ROM (Read Only Memory) device and a RAM (Random Access Memory) device, flash memory, etc. The storage devices store batter condition data condition data and battery monitoring program that is run by the at least one processor of the battery controller 80.

[0093] The motor 64 is preferably an electric reversible motor. For example, the motor 64 is preferably a 120 watt DC brushless motor that is configured to rotate at 3000 rpms to 3200 rpms. Preferably, the motor 64 is configured to produce a thrust of nine to ten pounds of force (i.e., eighteen to twenty pounds of force for two motors). The motor 64 is a direct drive motor that has an output shaft 82 with a propeller 84 fixedly mounted to the output shaft 82. The propeller 84 is located inside the propeller shroud 56 to form a ducted propeller, which is also known as a Kort nozzle. Here, the propeller 84 has three blades.

[0094] The battery 66 is electrically connected to the motor 64, the motor controller 68 and the sub-two-way communication device 70 for supplying electrical power thereto. The battery 66 is preferably a rechargeable Lithium Ion Battery or any other suitable electrical power supply.

The battery 66 preferably has a 21.6 volt battery with a 100 Wh capacity. With this battery configuration and the above-mentioned motor configuration, each of the submersible propulsion units 16A and 16B should be capable of at least about thirty minutes of runtime at the maximum speed of 3200 rpms.

[0095] As seen in FIGS. 9 to 12, the motor 64 has a pair of first electrical contacts 86 and 88 (e.g., a pair of male electrical connectors), while the battery 66 has a pair of second electrical contacts 90 and 92 (e.g., a pair of female electrical connectors). The first electrical contacts 86 and 88 mate with the second electrical contacts 90 and 92 for supplying electrical power from the battery 66 to the motor 64 when the motor unit 46 and the battery unit 48 are coupled together. In this way, the battery 66 is electrically connected to the motor 64.

[0096] To ensure good contact between the first electrical contacts 86 and 88 and the second electrical contacts 90 and 92, optionally, the first and second electrical contacts 86, 88, 90 and 92 can be configured to be pressed against each other, respectively, while the motor housing 50 and the battery housing 52 are joined. This pressing contact between the first electrical contacts 86 and 88 and the second electrical contacts 90 and 92 can be accomplished by spring loading the first electrical contacts 86 and 88 and/or spring loading the second electrical contacts 90 and 92 spring loaded. In the first embodiment, the first electrical contacts 86 and 88 are diagrammatically illustrated as being spring loaded with compression springs 93 as seen in FIG. 12. Alternatively, the first and second electrical contacts 86, 88, 90 and 92 can be configured to be pressed against each other, respectively, without using springs. For example, the motor housing 50 and the battery housing 52 can be configured such that plastic tension resulting from the connection of the motor housing 50 and the battery housing 52 can produce a biasing force that presses the first electrical contacts 86 and 88 and the second electrical contacts 90 and 92 together.

[0097] Also preferably, the motor 64 has a first communication electrical connector 94, while the battery 66 has a second communication electrical connector 96. The first communication electrical connector 94 mates with the second electrical contacts 96 for supplying battery condition data (e.g., current voltage) from the battery 66 to the motor 64 when the motor unit 46 and the battery unit 48 are coupled together. Also preferably, the battery 66 is provided with a charging connector 98 for connecting a battery charger (not shown). The motor unit 46 is provided with a dummy connector 100 that mates with the charging connector 98 when the motor unit 46 and the battery unit 48 are coupled together.

[0098] Here, the motor controller 68 in each of the submersible propulsion units 16A and 16B is depicted as a single unit or circuit board. However, the motor controller 68 can be constructed as two or more separate circuit boards that each has its own processor, if needed and/or desired. In any case, the motor controller 68 basically has at least one processor with at least one motor control program that controls the operations of the motor 64 in the corresponding one of the submersible propulsion units 16A and 16B. More preferably, the motor controller 68 in each of the submersible propulsion units 16A and 16B is a microcomputer that in addition to the at least one processor further includes other conventional components such as an input interface circuit, an output interface circuit, and storage devices, such as a

ROM (Read Only Memory) device and a RAM (Random Access Memory) device, flash memory, etc. The storage devices store processing results, motor condition data of the motor **64**.

[0099] The motor controller **68** is operatively connected to the sub-two-way communication device **70** to receive control signals or commands from the main controller **40** that are transmitted via the main two-way communication device **42** to the sub-two-way communication device **70**. The motor controller **68** is also operatively connected to the motor **64** to control the speed of the motor **64** based on the control signals or commands received from the main controller **40**. As result, the motor controller **68** is configured to control the speed of the motor **64**.

[0100] Also, the motor controller **68** receives operation and/or condition data from the motor **64**, the water leak detectors **72** and **74**, the motor speed detector **79** and the battery controller **80**. The operation and/or condition data received by the motor controller **68** is sent to the main controller **40** via wireless communication between the main two-way communication device **42** and the sub-two-way communication device **70**. While the main two-way communication device **42** and the sub-two-way communication devices **70** are wireless two-way communication devices, the portable main control module **14** and the submersible propulsion units **16A** and **16B** can be communicate using wires if needed and/or desired. In any case, the sub-two-way communication devices **70** are configured to communicate with the main two-way communication device **42** such that two-way communication is conducted.

[0101] In the first embodiment, as just mention, each of the sub-two-way communication devices **70** is a sub-two-way wireless communication device. Each of the sub-two-way communication devices **70** can be the same as the main two-way communication device **42**, which is discussed above. For example, the main two-way communication device **42** can be a Bluetooth® radio transceiver that includes both transmitter and receiver functions and that has an integrated antenna. In any case, the sub-two-way communication devices **70** are configured to conduct two-way communications with the main two-way communication device **42**. The sub-two-way communication device **70** is programmed to transmit both battery condition data (e.g., voltage, current, battery capacity and battery temperature) and motor condition data (e.g., actual output shaft rpm and motor temperature) as the propulsion unit data to the main two-way communication device **42**. The main controller **40** is programmed to output control signals to control the speeds of the motors **64** of the submersible propulsion unit **16A** and **16B** via the motor controllers **68** based on feedback signals containing propulsion unit data that is received from the first sub-two-way communication device **70**. In this way, the main controller **40** is programmed to independently control the speeds of the first and second motors **64** of the first and second submersible propulsion units **16A** and **16B** so as to ensure that the aquatic vessel moves along a straight path.

[0102] As seen in FIG. 13, each of the submersible propulsion units **16A** and **16B** can be provided with an additional battery unit **48'** having an additional battery housing **52'** that houses an additional battery **66'**, a water leak detector **74'** and an additional battery controller **80'**. The additional battery housing **52'** is configured to be attached in place of the battery housing **52** in each of the submersible

propulsion units **16A** and **16B**. The additional battery **66'** has a different storage capacity from the battery **66**. While the additional battery **66'** is illustrated as being smaller with a lower storage capacity than the battery **66**, the additional battery **66'** can be larger with a larger storage capacity than the battery **66** as needed and/or desired. Typically, as the storage capacity of the battery becomes smaller, the battery unit becomes lighter. In this way, the user can whether to use a heavier battery that will provide a longer runtime for the motor **64** based on the storage capacity of the battery, or a lighter battery that will provide a longer runtime for the motor **64** based on the storage capacity of the battery.

[0103] Alternatively, the each of the submersible propulsion units **16A** and **16B** can be provided with an additional battery unit **48''** that has an additional battery housing **52''** with an external battery **66''** that plugs into an electrical connector provided on the additional battery housing **52''**. The additional battery housing **52''** is configured to be attached in place of the battery housing **52** in each of the submersible propulsion units **16A** and **16B**. Here, similar to the other batteries **66** and **66'**, the additional battery housing **52''** houses a water leak detector **74''** and an additional battery controller **80''**. When using the additional battery unit **48''**, the external battery **66''** can be mounted on the above water level surface **20a** of the floating body **20**. In this way, the external battery **66''** can be made larger with a larger storage capacity than an internal battery such as the battery **66**.

[0104] Referring now to FIGS. 14 and 15, one example of a mounting bracket **102** is illustrated that is used for mounting each of the submersible propulsion units **16A** and **16B** to the aquatic vessel **12**. Of course, the submersible propulsion units **16A** and **16B** can be attached to the aquatic vessel **12** with other types of mounting arrangements. However, preferably, the submersible propulsion units **16A** and **16B** are attached to the aquatic vessel **12** in such a manner that the submersible propulsion units **16A** and **16B** can be easily detached from and reinstalled onto the aquatic vessel **12**.

[0105] Here, the mounting bracket **102** includes a first attachment part **104** and a second attachment part **106**. The first attachment part **104** is fixedly attached to the motor housing **50**, while the second attachment part **106** is fixedly attached to the below water level surface **20b** of the floating body **20** of the aquatic vessel **12**. In the first embodiment, the first attachment part **104** has a curved mounting surface **104b** that is fixedly attached to the motor housing **50** by an adhesive or any other suitable fastening means, such as threaded fasteners. In the first embodiment, the second attachment part **106** has a flat mounting surface **106b** that is fixedly attached to the below water level surface **20b** of the floating body **20** by an adhesive or any other suitable fastening means, such as threaded fasteners.

[0106] While the mounting surface **106b** of the second attachment part **106** is flat in the first embodiment, it will be apparent from this disclosure that the mounting surface **106b** of the second attachment part **106** can be contoured to match a surface of the aquatic vessel where one of the submersible propulsion units **16A** and **16B** is to be mounted. In fact, several second attachment parts with differently shaped mounting surfaces can be provided with each of the submersible propulsion units **16A** and **16B** so that the submersible propulsion units **16A** and **16B** can be mounted to various types of aquatic vessels.

[0107] The first and second attachment parts **104** and **106** are detachably connected using an interlocking tongue and groove connection. In particular, the first attachment part **104** has a pair of grooves **104b**, while the second attachment part **106** has a pair of T-shaped ribs **106b**. The grooves **104b** are closed at the rearward end and open at the forward end so that the ribs **106b** can slide into the grooves **104b** to secure the second attachment part **106** to the first attachment part **104**. The ribs **106b** are configured to snugly fit into the grooves **104b** such that the first and second attachment parts **104** and **106** are held together by friction.

[0108] Referring now to FIGS. **16** to **18**, a flow chart is illustrated to depict a control program that is executed by the main controller **40** of the portable main control module **14**. This control program is continuously executed by the main controller **40** once the portable main control module **14** is turned on. While the control process is illustrated as controlling only two submersible propulsion units, the control process can be used with any number (one or more) of the submersible propulsion units. Here, for the sake of simplicity, the submersible propulsion units **16A** and **16B** shall be simply referred to as the first and second propulsion units **16A** and **16B**.

[0109] Basically, in the flow chart depicted in FIGS. **16** to **18**, the main controller **40** is programmed to output first and second control signals to control the speeds of the first and second motors **64** of the first and second submersible propulsion units **16A** and **16B**, respectively, via the first and second motor controllers **68** based on first and second feedback signals containing first and second propulsion unit data that is received from the first and second sub-two-way communication devices **70**. The first and second propulsion unit data can include battery condition data (e.g., voltage, current, battery capacity and battery temperature) and motor condition data (e.g., actual output shaft rpm and motor temperature). Thus, for example, in the flow chart depicted in FIGS. **16** to **18**, the main controller **40** can calculate motor speeds of the motors **64** based on detection signals from the speed sensors **79**. Alternatively, the main controller **40** can estimate motor speeds of the motors **64** based on battery capacity and/or battery voltage. In any case, by using the first and second propulsion unit data, the main controller **40** can balance the thrust outputted by the first and second submersible propulsion units **16A** and **16B** such that the aquatic vessel **12** goes straight.

[0110] In step S1, the main controller **40** receives propulsion unit data of the first and second propulsion units **16A** and **16B** that are within the communication area of the portable main control module **14**. Specifically, each of the motor controllers **68** of the submersible propulsion units **16A** and **16B** is configured to transmit at least once a propulsion unit ID within the predetermined time from activation of the portable main control module **14** to initialize communication. Thus, once the user turns on the first and second propulsion units **16A** and **16B** using the on/off switches **76**, the sub-two-way communication devices **70** of the first and second propulsion units **16A** and **16B** will start transmitting the propulsion unit ID's.

[0111] In step S2, the main controller **40** determines if a malfunction signal is received from one of the first and second propulsion units **16A** and **16B**. Specifically, the first and second propulsion units **16A** and **16B** will transmit a malfunction signal if one of the water leak detectors **72** or **74** detects a leak in one of the first and second propulsion units

**16A** and **16B**. Also, the first and second propulsion units **16A** and **16B** will transmit a malfunction signal upon determining that an overcurrent condition and/or an over-voltage condition exists in one of the first and second propulsion units **16A** and **16B**. In addition, the first and second propulsion units **16A** and **16B** will transmit a malfunction signal upon determining that the fuse **78** has blown in one of the first and second propulsion units **16A** and **16B**. Moreover, the first and second propulsion units **16A** and **16B** will transmit a malfunction signal upon determining that the battery capacity of one of the batteries **66** is below a prescribed threshold in one of the first and second propulsion units **16A** and **16B**. Thus, the main controller **40** is programmed to stop the first and second submersible propulsion units **16A** and **16B** at the same time upon detecting one of the first and second submersible propulsion units **16A** and **16B** being an unintentional stop condition (overcurrent condition existing, low battery capacity, fuse blown, etc.). If the main controller **40** receives a malfunction signal, then the process proceeds to step S3. However, if the main controller **40** does not receive a malfunction signal, then the process proceeds to step S4.

[0112] In step S3, the main controller **40** execute a failsafe mode. Here, the failsafe mode can merely be the main controller **40** transmitting stop signals to the first and second propulsion units **16A** and **16B**.

[0113] In step S4, the main controller **40** execute a recognition process of the number of propulsion units. The main controller **40** is programmed to identify the submersible propulsion units **16A** and **16B** to be controlled within a predetermined time from activation of the portable main control module **14**. In the recognition process, the main controller **40** conducts a pairing process and stores the propulsion unit ID's in memory so that the pairing process does not need to be conducted in subsequent uses of the aquatic jet propulsion device **10**. Thus, in the first embodiment, the main controller **40** will recognize two propulsion units (i.e., the first and second propulsion units **16A** and **16B**) if they are functioning properly and have sufficient battery capacities. Also in the recognition process, the main controller **40** determines the control procedure to be used to control the speeds of the propulsion units based on the number of propulsion units that are recognized. Accordingly, the main controller **40** determines the location and number of the propulsion units being used.

[0114] In step S5, the main controller **40** determines if the number of signals equal to the number of propulsion units. The main controller **40** is programmed to identify the submersible propulsion units **16A** and **16B** to be controlled within a predetermined time from activation of the portable main control module **14**. If the main controller **40** determines the number of signals is not equal to the number of propulsion units (e.g., communication with one of the submersible propulsion units **16A** and **16B** has stopped), then the process proceeds to step S3 to execute the failsafe mode in which the main controller is programmed to stop both of the first and second motors of the first and second submersible propulsion units upon loss of communication with one of the first and second motors **64** of the first and second submersible propulsion units **16A** and **16B**. However, if the main controller **40** determines the number of signals is equal to the number of propulsion units, then the process proceeds to step S6.

[0115] In step S6, the main controller 40 receives the propulsion unit data of all recognized propulsion units and stores the propulsion unit data. In this way, the main controller 40 receives all of the battery voltages of the batteries 66 so as to determine if the speeds of the motors 64 may need to be limited. Then the process proceeds to step S7.

[0116] In step S7, based on the current propulsion unit data, the main controller 40 calculates a first maximum motor speed RPM1 for the first propulsion unit 16A based on the voltage received from the first propulsion unit 16A and a second maximum motor speed RPM2 for the second propulsion unit 16B based on the voltage received from the second propulsion unit 16B. Alternatively, the main controller 40 can calculate the first and second maximum motor speeds RPM1 and RPM2 for the first and second propulsion units 16A and 16B based on the battery capacities of the batteries 66 of the first and second propulsion units 16A and 16B. Then the process proceeds to step S8.

[0117] In step S8, the main controller 40 determines if a speed signal inputted has been inputted by the user using the user input interface 26. If no speed signal is inputted by a user, then the process returns to step S1 to restart the process. However, if a speed signal is inputted by a user, then the process proceeds to step S9.

[0118] In step S9, the main controller 40 calculate a first target motor speed RPMT1 for the first propulsion unit 16A and a second target motor speed RPMT2 for the second propulsion unit 16B to achieve target input speed that the user inputted. Then the process proceeds to step S10.

[0119] In step S10, the main controller 40 determines if the first and second target motor speeds RPMT1 and RPMT2 are equal to or less than the first and second maximum motor speeds RPM1 and RPM2 (i.e.,  $RPMT1 \leq RPM1$  and  $RPMT2 \leq RPM2$ ). If the main controller 40 determines that both of the first and second target motor speeds RPMT1 and RPMT2 are equal to or less than the first and second maximum motor speeds RPM1 and RPM2, then the main controller 40 determines that the speeds of the motors 64 do not need to be limited and the process proceeds to step S11.

[0120] In step S11, the main controller 40 transmits the target motor speeds RPMT1 and RPMT2 to the first and second propulsion units 16A and 16B, respectively. In this way, the main controller 40 can make sure that the aquatic vessel 12 moves in a straight path. Then the process returns to step S1 to restart the process.

[0121] However, in step S10, if the main controller 40 determines that one of the first and second target motor speeds RPMT1 and RPMT2 is greater than the first and second maximum motor speeds RPM1 and RPM2, then the main controller 40 determines that the speeds of the motors 64 need to be limited to the lower value of the first and second maximum motor speeds RPM1 and RPM2. By repeating step S10 in each cycle, the main controller 40 uses feedback control to adjust the voltage to the motors 64 of the first and second propulsion units 16A and 16B, respectively, based on one or more of the detection results from the motor speed detectors 79, the motor condition data and the battery condition data. Here, for example, the main controller 40 is programmed to use the first and second voltage data to control the speeds of the first and second motors 64 of the first and second submersible propulsion units 16A and 16B to be substantially equal for going straight. Alternatively, the main controller 40 is programmed to use the first and second

motor data to control the speeds of the first and second motors 64 of the first and second submersible propulsion units 16A and 16B to be substantially equal. In either case, the main controller 40 is programmed to control the speeds of the first and second motors 64 of the first and second submersible propulsion units 16A and 16B to be substantially equal upon determining an operator's intention to go straight in either a forward direction or a backward direction. In particular, the main controller 40 is programmed to adjust the speed of one of the first and second motors 64 of the first and second submersible propulsion units 16A and 16B using feedback control based on the other of the first and second motors 64 of the first and second submersible propulsion units 16A and 16B upon determining the other of the first and second motors 64 of the first and second submersible propulsion units 16A and 16B has a smaller speed output than the one of the first and second motors 64 of the first and second submersible propulsion units 16A and 16B. Alternatively, in step S11, the main controller 40 is programmed to adjust the speed of one of the first and second motors 64 of the first and second submersible propulsion units 16A and 16B using feedback control based on the other of the first and second motors 64 of the first and second submersible propulsion units 16A and 16B upon determining the other of the first and second motors 64 of the first and second submersible propulsion units 16A and 16B has a smaller battery capacity than the one of the first and second motors 64 of the first and second submersible propulsion units 16A and 16B. Thus, the process proceeds to step S12.

[0122] In step S12, the main controller 40 determines if the user wants to move forward or reverse in a straight path or wants to turn. In particular, the main controller 40 determines if the first and second target motor speeds RPMT1 and RPMT2 are equal or not (i.e.,  $RPMT1 = RPMT2$ ). If the first and second target motor speeds RPMT1 and RPMT2 are equal, then the user wants to go straight and the process proceeds to step S13. However, if the first and second target motor speeds RPMT1 and RPMT2 are not equal then the user wants to turn and the process proceeds to step S17.

[0123] In step S13, the main controller 40 determines which of the first and second maximum motor speeds has the lower value (i.e.,  $RPM1 > RPM2$ ). If the main controller 40 determines the first maximum motor speed RPM1 has the lower value, then process proceeds to step S14 where the main controller 40 transmit the motor speed RPM1 to all propulsion units 16A and 16B. However, if the main controller 40 determines the second maximum motor speed RPM2 has the lower value, then process proceeds to step S14 where the main controller 40 transmit the motor speed RPM1 to all propulsion units 16A and 16B. Then after steps S14 and S15, the process proceeds to step S16.

[0124] In step S16, the main controller 40 activates the battery condition indicator 35 to indicate the motor speed is limited due to a low battery condition of one of the batteries 66. Then the process returns to step S1 to restart the process.

[0125] However, in step S12, if the first and second target motor speeds RPMT1 and RPMT2 are not equal then the user wants to turn and the process proceeds to step S17. In step S17, the main controller 40 calculates the motor speed difference  $\Delta RPM$  between the first maximum motor speed RPM1 and the second maximum motor speeds RPM2 (i.e.,  $\Delta RPM = |RPM1 - RPM2|$ ). Then the process proceeds to step S18.

[0126] In step S18, the main controller 40 determines if the first target motor speed  $RPMT1$  is greater than the first maximum motor speed  $RPM1$  (i.e.,  $RPMT1 > RPM1$ ). If the first target motor speed  $RPMT1$  is greater than the first maximum motor speed  $RPM1$ , then the main controller 40 determines that the speed of the motor 64 of the first propulsion unit 16A is limited by the first maximum motor speed  $RPM1$  of the first propulsion unit 16A. Thus, the process proceeds to step S19 to determine the speed of the motor 64 of the second propulsion unit 16B.

[0127] In step S19, the main controller 40 determines the speed of the motor 64 of the second propulsion unit 16B by comparing the first maximum motor speed  $RPM1$  minus the motor speed difference  $\Delta RPM$  to the second maximum motor speed  $RPM2$  (i.e.,  $RPM1 - \Delta RPM \leq RPM2$ ). If the main controller 40 determines the first maximum motor speed  $RPM1$  minus the motor speed difference  $\Delta RPM$  is less than or equal to the second maximum motor speed  $RPM2$ , then the process proceeds to step S21 and transmits the motor speed  $RPM1$  to the first propulsion unit 16A and the motor speed  $RPM1 - \Delta RPM$  to the second propulsion unit 16B. On the other hand, if the main controller 40 determines the first maximum motor speed  $RPM1$  minus the motor speed difference  $\Delta RPM$  is greater than the second maximum motor speed  $RPM2$ , then the process proceeds to step S22 and transmits the motor speed  $RPM1$  to the first propulsion unit 16A and the motor speed  $RPM2$  to the second propulsion unit 16B.

[0128] However, in step S18, if the first target motor speed  $RPMT1$  is less than the first maximum motor speed  $RPM1$ , then the main controller 40 determines that the speed of the motor 64 of the first propulsion unit 16A is not limited by the first maximum motor speed  $RPM1$  of the first propulsion unit 16A. Rather, the main controller 40 determines that the speed of the motor 64 of the second propulsion unit 16B is limited by the second maximum motor speed  $RPM2$  of the second propulsion unit 16B. Thus, the process proceeds to step S20.

[0129] In step S20, the main controller 40 determines if determines the speed of the motor 64 of the first propulsion unit 16A by comparing the second maximum motor speed  $RPM2$  minus the motor speed difference  $\Delta RPM$  to the first maximum motor speed  $RPM1$  (i.e.,  $RPM2 - \Delta RPM \leq RPM1$ ). If the main controller 40 determines the second maximum motor speed  $RPM2$  minus the motor speed difference  $\Delta RPM$  is greater than the first maximum motor speed  $RPM1$ , then the process proceeds to step S22 and transmits the motor speed  $RPM1$  to the first propulsion unit 16A and the motor speed  $RPM2$  to the second propulsion unit 16B. On the other hand, if the main controller 40 determines the second maximum motor speed  $RPM2$  minus the motor speed difference  $\Delta RPM$  is equal to or less than the first maximum motor speed  $RPM1$ , then the process proceeds to step S23 and transmits the motor speed  $RPM2 - \Delta RPM$  to the first propulsion unit 16A and the motor speed  $RPM2$  to the second propulsion unit 16B.

[0130] In step S22, the main controller 40 transmits the motor speed  $RPM1$  to the first propulsion unit 16A and the motor speed  $RPM2$  to the second propulsion unit 16B.

[0131] In step S23, the main controller 40 transmits the motor speed  $RPM2 - \Delta RPM$  to the first propulsion unit 16A and the motor speed  $RPM2$  to the second propulsion unit 16B.

[0132] In steps S21, S22 and S23, the main controller 40 is programmed to make a turn by reversing thrust of one of the first and second motors 64 of the first and second submersible propulsion units 16A and 16B while maintaining thrust of the other of the first and second motors 64 of the first and second submersible propulsion units 16A and 16B in a forward direction.

[0133] After each of the steps S21, S22 and S23, the process proceeds to step S16, where the main controller 40 activates the battery condition indicator 35 to indicate the motor speed is limited due to a low battery condition of one of the batteries 66. Then the process returns to step S1 to restart the process.

[0134] In performing a turn, typically, the motor 64 located on the side in the direction of the turn will be reversed to aid in turn in the desired direction. However, in performing a rapid 180 degree turn, the main controller 40 is programmed to reverse the thrust of the one of the first and second motors 64 of the first and second submersible propulsion units 16A and 16B that is determined to have a smaller speed output. Alternatively, in performing a rapid 180 degree turn, the main controller 40 is programmed to reverse the thrust of the one of the first and second motors 64 of the first and second submersible propulsion units 16A and 16B that is determined to have a smaller battery capacity. With this alternative programming the aquatic vessel 12 can be turn rapidly by using the motor 64 of the first and second submersible propulsion units 16A and 16B that has the highest maximum thrust in a forward driving direction and using the motor 64 of the first and second submersible propulsion units 16A and 16B with the lower thrust in a rearward driving direction.

[0135] Referring now to FIG. 19, an aquatic jet propulsion device 10A is illustrated in accordance with another embodiment. Here, the aquatic jet propulsion device 10A comprises a portable main control module 14A and the submersible propulsion units 16A and 16B of the first embodiment. The portable main control module 14A is identical to the portable main control module 14 of the first embodiment except that the portable main control module 14A is configured to be worn on a user's waist and further comprises a tether T. The tether T has a first end T1 configured to be attached to the aquatic vessel 12 and a second end T2 attached to the portable main control module 14A. Preferably, the tether T is detachably mounted to the portable main control module 14A such that detachment of the tether T from the portable main control module 14 inputs a signal to the main controller 40 to indicate that the tether T has been detached from portable main control module 14A. The second end T2 of the tether T can be attached to the portable main control module 14A by a magnet. The portable main control module 14A can include a magnetic sensor as in one of the later embodiments to detect the detachment of the tether T from the portable main control module 14. Upon detachment of the tether T from the portable main control module 14, the main controller 40 will stop the submersible propulsion units 16A and 16B. Alternatively, the magnet and the magnetic sensor can be provided at the first end T1 of the tether T where the tether T is attached to the aquatic vessel 12. In other words, the main controller 40 is programmed to stop both of the first and second motors 64 of the first and second submersible propulsion units 16A and 16B upon detachment of the tether T from one of the aquatic vessel 12 and the portable main control module 14. Alternatively, the stopping of the motors

can be based on the distance of the magnet from the magnetic sensor rather than the mere detachment of the tether T. In this case, the main controller 40 is programmed to stop both of the first and second motors 64 of the first and second submersible propulsion units 16A and 16B upon determining a distance of between the portable main control module 14 and one of the first and second submersible propulsion units 16A and 16B is greater than a prescribed distance threshold.

[0136] Referring now to FIG. 20, a portable main control module 14B is provided with a joint movement input device 15. The portable main control module 14B is identical to the portable main control module 14 of the first embodiment except for the addition of the joint movement input device 15. The joint movement input device 15 has an input member 15a and a joint attachment 15b. The input member 15a inputs a control signal to the main controller 40 upon being flexed. While the joint attachment 15b configured to be mounted to a user's finger, it will be apparent from this disclosure that the joint attachment 15b can be configured to be used with any joint. In one embodiment, the joint movement input device 15 is a speed input control device that sends a speed control signal to the main controller 40 based on the amount that the user's finger is bent. When the user's finger is straight, the main controller 40 will stop the motors 64 of each of the submersible propulsion units 16A and 16B. The more the user's finger is bent, the faster the main controller 40 will operate the motors 64.

[0137] Referring now to FIGS. 21 and 22, an aquatic jet propulsion device 10' is illustrated in accordance with another embodiment. Here, the aquatic jet propulsion device 10' comprises the portable main control module 14 of the first embodiment and a pair submersible propulsion units 16A' and 16B'. The submersible propulsion units 16A' and 16B' are attached to the below water level surface 20b with the floating body 20 of the aquatic vessel 12 in the same manner as in the first embodiment as discussed above. The submersible propulsion units 16A' and 16B' are identical to each other, and each includes a motor unit 46' and a battery unit 48' that are connected together in the same manner that the motor unit 46 and the battery unit 48 are connected together in the first embodiment as discussed above. The motor unit 46' includes the motor 64, the motor controller 68, the water leak detector 72, the on-off switch 76 and the fuse 78 of the first embodiment as discussed above. The battery unit 48' includes the battery 66, the water leak detector 74 and the battery controller 80 of the first embodiment as discussed above. Thus, the submersible propulsion units 16A' and 16B' are identical to the submersible propulsion units 16A and 16B of the first embodiment, except that a common sub-two-way communication device 70' is provided that is shared by each of the submersible propulsion units 16A' and 16B'. The sub-two-way communication device 70' is at least partially located outside of the housings the submersible propulsion units 16A' and 16B' on the above water level surface 20a. In particular, the motors 64 and the batteries 66 of the submersible propulsion units 16A and 16B are disposed underneath the below water level surface 20b of the floating body 20, while the sub-two-way communication device 70 is disposed above the above water level surface 20a of the floating body 20. The sub-two-way communication device 70' is electrically connected to the submersible propulsion units 16A' and 16B' by a pair of electrical wires W1 and W2. In this way, the sub-two-way

communication device 70' can communicate with the main two-way communication device 42 of the portable main control module 14 without the wireless signal degrading due to the effect of the air to water interface.

[0138] Referring now to FIGS. 23 and 24, an aquatic jet propulsion device 110 is illustrated in accordance with another embodiment. Here, the aquatic jet propulsion device 110 is installed on the aquatic vessel 12 of the first embodiment. Here, the aquatic jet propulsion device 110 comprises a portable main control module 114 and the submersible propulsion units 16A and 16B of the first embodiment. The portable main control module 114 is detachably mounted to the above water level surface 20a of the floating body 20 by a suitable fastener such as a hook and loop fastener. The portable main control module 114 includes the user input interface 26 of the first embodiment which includes the main on-off switch 30, the forward input 31, the rearward input 32, the left turn input 33, the right turn input 34, the battery condition indicator 35 and the leak indicator 36, which are all discussed above. The portable main control module 114 further includes the main controller 40, the main two-way communication device 42 and the battery 44, which are all discussed above. Accordingly, the portable main control module 114 is identical to the portable main control module 14 of the first embodiment, except that the portable main control module 114 is configured to be mounted on the aquatic vessel 12 and the portable main control module 114 further includes an operator movement detector MS. The operator movement detector MS is a magnetic sensor that is configured to sense the presence or absence of that a magnetic field produced by a magnet M. The magnet M is disposed on one end of a tether T that has an operator attachment portion 115 at the other end. Thus, the tether T has a first end configured to be attached to an operator and a second end attached to the portable main control module 114. The magnet M is detachable held on the operator movement detector MS by a magnetic field of the operator movement detector MS. In this way, the magnetic sensor MS can detect whether or not the user or operator of the aquatic vessel 12 is in the correct position and/or orientation for using or operating the aquatic vessel 12. In particular, if the magnet M of the tether T is pulled off of the portable main control module 114, then a detection signal is generated by the operator movement detector MS. This detection signal is sent to the main controller 40. Then, the main controller 40 is programmed to stop both of the motors 64 of the first and second submersible propulsion units 16A and 16B upon receiving detection signal from the magnetic sensor 110a of the operator movement detector 110 that is indicative of an operator or user being in a non-operating orientation. Here, the main controller 40 is programmed to stop both of the first and second motors 64 of the first and second submersible propulsion units 16A and 16B upon detachment of the tether T from one of the operator and the portable main control module 114.

[0139] Referring now to FIGS. 25 to 27, an aquatic jet propulsion device 210 is illustrated in accordance with another embodiment. Here, the aquatic jet propulsion device 210 is installed on a kayak 212, which is another example of an aquatic vessel. The aquatic jet propulsion device 210 comprises a portable main control module 214 and a pair submersible propulsion units 216A and 216B. The submersible propulsion units 216A and 216B are identical to the submersible propulsion units 16A and 16B of the first

embodiment. The portable main control module 214 includes the user input interface 26 of the first embodiment which includes the main on-off switch 30, the forward input 31, the rearward input 32, the left turn input 33, the right turn input 34, the battery condition indicator 35 and the leak indicator 36, which are all discussed above. The portable main control module 214 further includes the main controller 40, the main two-way communication device 42 and the battery 44, which are all discussed above. Accordingly, the portable main control module 214 is identical to the portable main control module 14 of the first embodiment, except that the portable main control module 214 includes a paddle attachment 224 that is configured to be attached to the paddle 18, and includes a paddle movement sensor 245 (e.g., an accelerometer). The accelerometer 245 detects the paddling motion by the user. The paddling motion data of the accelerometer 245 is inputted to the main controller 40, which then can operate the motors of the submersible propulsion units 216A and 216B in accordance with paddling motion by the user to assist the paddling motion.

[0140] The aquatic vessel 212 comprises a V-shaped hull as a floating body 220 having an above water level surface 220a and a below water level surface defined by a first slanted surface 220b and a second slanted surface 220c. A first one of the submersible propulsion units 16A and 16B is attached to the first slanted surface 220b and a second one of the submersible propulsion units 16A and 16B is attached to the second slanted surface 220c. Here, the submersible propulsion units 16A and 16B are attached to the first and second slanted surfaces 220b and 220c by two mounting brackets 217 that are identical to the mounting brackets 102 shown in FIGS. 14 and 15.

[0141] Referring now to FIG. 28, the aquatic jet propulsion device 10 of the first embodiment is illustrated as being installed on an aquatic vessel 312 in the form of an inflatable pontoon boat. Here, the submersible propulsion units 16A and 16B are attached to the aquatic vessel 312 using the mounting bracket 102 shown in FIGS. 14 and 15.

[0142] Referring now to FIG. 29, the aquatic jet propulsion device 10 of the first embodiment is illustrated as being installed on a diver's thighs. Here, the submersible propulsion units 16A and 16B are attached to the diver's thighs by a pair of attachment members 17' that form an aquatic vessel. The attachment members 17' are configured to mate with the first attachment parts 104 of the submersible propulsion units 16A and 16B.

[0143] Referring now to FIGS. 30 and 31, a submersible propulsion unit 416 is illustrated in accordance with another illustrated embodiment. Here, the submersible propulsion unit 416 includes a motor-battery unit 446 that can have either an end cap 447 (FIG. 30) attached thereto, or an additional battery unit 449 (FIG. 31) attached thereto.

[0144] The motor-battery unit 446 is identical to the motor unit 46 as discussed above, except that the motor-battery unit 446 has an extended motor housing 450 that houses an internal battery 451 and a battery controller 453 in addition to the component of the motor unit 46 of the first embodiment. Thus, the motor-battery unit 446 includes a motor 464, a motor controller 468, a sub-two-way communication device 470, a water leak detector 472, an on-off switch 476 and a fuse 478. Since the motor 464, the motor controller 468, the sub-two-way communication device 470, the water leak detector 472, the on-off switch 476 and the fuse 478 are identical to the corresponding components in the motor unit

46 of the first embodiment, these components will not be discussed for the sake of brevity. Similar to the first embodiment, the submersible propulsion unit 416 has a motor speed detector (not shown). Also, the motor 464 has an output shaft 482 with a propeller 484 fixedly mounted to the output shaft 482 in the same manner as the first embodiment.

[0145] The end cap 447 and the additional battery unit 449 are attached to the motor-battery unit 446 in the same manner that the battery unit 48 is attached to the motor unit 46. However, the end cap 447 does not include any electrical components, but rather is designed to protect the electrical contacts of the motor-battery unit 446. On the other hand, the additional battery unit 449 has a battery housing 491 that contains at least one additional battery 492.

[0146] Referring now to FIGS. 32 to 39, an aquatic jet propulsion device 510 is provided on an aquatic vessel 512 in accordance with another illustrated embodiment. Here, the aquatic vessel 512 is a stand up paddle (SUP) board. However, it will be apparent to those skilled in the field of aquatic jet propulsion devices from this disclosure that the aquatic jet propulsion device 510 can be used with other types of aquatic vessels, and thus are not limited to any particular aquatic vessels. The aquatic jet propulsion device 510 comprises a control module 514 and a plurality (two) of submersible propulsion units 516. Here, in this embodiment, the aquatic jet propulsion device 510 further comprises a communication device 517 that is provided on the aquatic vessel 512. As explained below, the communication device 517 is a wireless repeater that wirelessly receives signals from the control module 514 and the submersible propulsion units 516 and wirelessly transmits the existing signals that were received to the control module 514 and the submersible propulsion units 516. The aquatic vessel 512 also includes a stand up paddle 518 that includes the control module 514.

[0147] Here, in this embodiment, the basic configuration of the control module 514 is the same as the portable main control module 14, as discussed above and shown in FIG. 3, except that the control module 514 has been reconfigured to be integrated into the paddle 518, as explained below. Thus, the portable main control module 14 can be used to operate the submersible propulsion units 516, instead of using the control module 514. If the portable main control module 14 is used to operate the submersible propulsion units 516, then the portable main control module 14 can be either worn by the user or provided on the paddle 18 as mentioned above.

[0148] As diagrammatically seen in FIG. 35, the control module 514 includes a user input interface 526, a display 538, an electronic controller 540, a wireless communication device 542 and a battery 544. Here, the user input interface 526 includes a first twistable input 524A and a second twistable input 524B. In the illustrated embodiment, the first twistable input 524A is used to control the speed of the submersible propulsion units 516, while the second twistable input 524B is used to select a mode of operation of the submersible propulsion units 516. For example, with the second twistable input 524B, a user can select an "ON" mode, an "OFF" mode, a motor assist mode, a right turning mode, a left turning mode and a reverse mode. The wireless communication device 542 outputs wireless control signals to the communication device 517 which in turn wirelessly transmits the control signals to the submersible propulsion units 516. The wireless communication device 542 also receives wirelessly control signals from the submersible



propulsion units **516** via the communication device **517**. Thus, the wireless communication device **542** is a two-way wireless transceiver.

[0149] Here, in this embodiment, the basic configuration of the submersible propulsion units **516** is the same as the submersible propulsion units **16A** and **16B**, as discussed above and shown in FIG. 4, except that the submersible propulsion units **516** are each provided with an external antenna **516a** for wirelessly communicating with the communication device **517**. In other words, each of the submersible propulsion units **516** includes the motor unit **46** and the battery unit **48** discussed above.

[0150] Thus, the parts of the submersible propulsion units **516** that are the same as the submersible propulsion units **16A** and **16B** will not be discussed herein for the sake of brevity. Also, similar to the first embodiment, it will be apparent to those skilled in the aquatic field from this disclosure that the aquatic jet propulsion device **510** can be configured with only a single one of the submersible propulsion units **516**, or more than two of the submersible propulsion units **516**, as needed and/or desired for the particular aquatic vessel.

[0151] By providing the external antennas **516a**, the interference to the wirelessly communications caused by the water can be reduced as compared to internal antennas as in the case of the submersible propulsion units **16A** and **16B**. Each of the submersible propulsion units includes a wireless communication device (i.e., the sub-two-way communication device **70** of FIG. 4) that wirelessly receives communications from the communication device **517**. Using the external antennas **516a**, the sub-two-way communication devices **70** of the submersible propulsion units **516** can wirelessly receive signals (i.e., communications) from the communication device **517** and wirelessly transmit signals (i.e., communications) to the communication device **517**. Also, preferably, the external antennas **516a** disposed near the communication device **517**. In the illustrated embodiment of FIGS. 32 to 34, the external antennas **516a** are vertically aligned with the communication device **517** as viewed in a direction particular to a fore-aft direction of the aquatic vessel **512** (i.e., the external antennas **516a** and the communication device **517** lie in a vertical plane that is direction particular to a vertical fore-aft plane of the aquatic vessel **512**).

[0152] The aquatic vessel **512** comprises a floating body **520** having an above water level surface **520a** and a below water level surface **520b**. The submersible propulsion units **516** are attached to the below water level surface **520b**. Similar to the first embodiment, the submersible propulsion units **516** are preferably configured to be detachable and reinstallable to the below water level surface **520b** without damaging the floating body **520**. Of course, if needed and/or desired, the aquatic jet propulsion device **510** can be an integrated part of an aquatic vessel. The communication device **517** is disposed above the above water level surface **520a** of the floating body **520**. The communication device **517** is configured to wirelessly communicate with the control module **514**, and is configured to wirelessly communicate with the submersible propulsion units **516**.

[0153] As diagrammatically seen in FIG. 36, the communication device **517** basically includes a communication circuit **CC** and an antenna **A**. The communication circuit **CC** and the antenna **A** are provided on a printed circuit board **PCB**. Preferably, the communication device **517** includes a

pair of rechargeable batteries **B** that electrically connected to electric contacts of the printed circuit board **PCB**. The rechargeable batteries **B** supply electrical power to the communication circuit **CC** and the antenna **A** via circuitry of the printed circuit board **PCB**. The communication device **517** also preferably includes a kill switch **SW** for stopping the motors **64** (see block diagram of FIG. 4) of the submersible propulsion units **516**.

[0154] As seen in FIGS. 37 and 38, the communication device **517** includes a vessel mount **517a** and a housing **517b**. The vessel mount **517a** is fixedly attached to the floating body **520** by an adhesive or any other suitable fastener(s). The housing **517b** is releasably attached to the vessel mount **517a** via a bayonet or twist-on connection. Alternatively, other types of releasably connections can be used to remove and reinstall the housing **517b** on the vessel mount **517a**. In any case, in the illustrated embodiment, the housing **517b** of the communication device **517** is detachably and reattachably coupled to the floating body **520** via the vessel mount **517a**. By having both the submersible propulsion units **516** and the communication device **517** releasably and reinstallably mounted to the floating body **520**, the submersible propulsion units **516** and the communication device **517** can be moved to other vessels having similar vessel mounts. In other words, the submersible propulsion units **516** and the communication device **517** can be swapped between different vessels by merely providing each of the vessels with similar vessel mounts.

[0155] As seen in FIGS. 37 and 39, the housing **517b** of the communication device **517** includes a cover **517b1** (shown in FIG. 35) and a base **517b2** (shown in FIG. 37). The cover **517b1** (shown in FIG. 35) is removably attached to the base **517b2** by a press-fit or a snap-fit. As seen in FIG. 37, the base **517b2** of the housing **517b** supports the rechargeable batteries **B** and the printed circuit board **PCB** that includes the communication circuit **CC** and the antenna **A**. When the cover **517b1** is provided on the base **517b2** as shown in FIG. 37, preferably a watertight seal (not shown) is provided between the cover **517b1** and the base **517b2**.

[0156] As seen in FIGS. 32 and 37 to 39 and as mentioned above, the communication device **517** also includes the kill switch **SW** for stopping the motors **64** of the submersible propulsion units **516**. In particular, the kill switch **SW** of the communication device **517** is operated by a tether **T** that extends between the communication device **517** and a user of the aquatic vessel **512**. In particular, the tether **T** has a first end **T1** detachably mounted to the kill switch **SW** of the communication device **517** via a clip **C**, and a second end **T2** having a user attachment **S** for attachment to a user. Upon detachment of the first end **T1** of the tether **T** from the communication device **517**, the communication device **517** outputs a wireless signal to the controllers of the submersible propulsion units **516** to stop the motors of the submersible propulsion units **16**. In this way, the submersible propulsion units **516** are configured to stop propulsion of the submersible propulsion units **516** upon the tether **T** being detached from the communication device **517**.

[0157] Referring to FIG. 40, a modified aquatic vessel **512'** (i.e., a stand up paddle board) is illustrated that is provided with the aquatic jet propulsion device **510** that includes the submersible propulsion units **516** and the aquatic vessel **512'** of the illustrated embodiment of FIGS. 32 to 34. Basically, the aquatic vessels **512** and **512'** are identical except for the mounting of the submersible propulsion units **516**. Here, in

the embodiment of FIG. 38, the aquatic vessel 512' comprises a floating body 520' having an above water level surface 520a' and a below water level surface 520b'. The below water level surface 520b' has a pair of recesses R for receiving the external antennas 516a of the submersible propulsion units 516. In this way, the external antennas 516a of the submersible propulsion units 516 can be disposed at or above the waterline when the aquatic vessel 512' is being used.

[0158] Referring now to FIGS. 41 to 44, an aquatic jet propulsion device 610 is provided on an aquatic vessel 612 in accordance with another illustrated embodiment. Here, the aquatic vessel 612 is a stand up paddle (SUP) board. However, it will be apparent to those skilled in the field of aquatic jet propulsion devices from this disclosure that the aquatic jet propulsion device 610 can be used with other types of aquatic vessels, and thus are not limited to any particular aquatic vessels. Basically, the aquatic jet propulsion device 610 is a modification of the illustrated embodiment of FIGS. 21 and 22.

[0159] As seen in FIGS. 41 and 42, the aquatic jet propulsion device 610 comprises a plurality (two) of submersible propulsion units 616 that are used with the control module 514 of the stand up paddle 518. Alternatively, the aquatic jet propulsion device 610 can be used with one of the control modules 14, 14A and 214. Here, in this embodiment, the aquatic jet propulsion device 610 further comprises a communication device 617 that is provided on the aquatic vessel 612, similar to the sub-two-way communication device 70' of FIGS. 21 and 22. The submersible propulsion units 616 are the same as the submersible propulsion units 16A' and 16B', discussed above. In other words, each of the submersible propulsion units 616 includes the motor unit 46' having the battery housing 50 and the battery unit 48' having the battery housing 52 discussed above. In this way, each of the submersible propulsion units 616 includes at least one housing containing the motor 64 and the battery 66 electrically connected to the motor 64. Accordingly, the submersible propulsion units 616 are the same as the submersible propulsion units 516, except that the communication device 617 is wired to the submersible propulsion units 616 to relaying the communication signals from the control module 514 to the submersible propulsion units 616.

[0160] As seen in FIG. 44, the communication device 617 is basically identical to the communication device 517, except that the communication device 617 does not wirelessly communicate with the submersible propulsion units 616. Rather, the communication device 617 communicate with the submersible propulsion units 616 via a pair of electrical wires W1 and W2. The communication device 617 includes the communication circuit CC, the antenna A and the kill switch of the communication device 517. However, since the communication device 617 is connected to the submersible propulsion units 616 via wires W1 and W2, the rechargeable batteries B can be omitted as explained below. Basically, the communication device 617 wirelessly receives signals from the control module 514 and transmits the existing signals that were received from the control module 514 to the submersible propulsion units 616 via the electrical wires W1 and W2. In other words, the communication device 617 is wired to the submersible propulsion units 616 for relaying communication signals from the control module 514 to the submersible propulsion units 616. More specifically, the communication device 617 is electrically con-

nected to the submersible propulsion units 616 by the electrical wires W1 and W2 similar to the embodiment of FIGS. 21 and 22. In this way, the submersible propulsion units 616 can communicate with the main two-way communication device of the control module 514 via the communication device 617 without the wireless signal degrading due to the effect of the air to water interface. In other words, the communication device 617 is configured relaying communication signals from the control module 514 to the submersible propulsion units 616 via electrical wires W1 and W2, and configured to wirelessly communicate communication signals from the submersible propulsion units 616 to the control module 514. Here, the electrical wires W1 and W2 are detachably connected to the submersible propulsion units 616 and the communication device 617 with threaded connectors provided at each end of the electrical wires W1 and W2. In this way, the communication device 617 can be easily connected, disconnected and reconnected with the submersible propulsion units 616.

[0161] The aquatic vessel 612 comprises a floating body 620 having an above water level surface 620a and a below water level surface 620b. The submersible propulsion units 616 are attached to the below water level surface 620b. Similar to the first embodiment, the submersible propulsion units 616 are preferably configured to be detachable and reinstallable to the below water level surface 620b without damaging the floating body 620. Of course, if needed and/or desired, the aquatic jet propulsion device 510 can be an integrated part of an aquatic vessel. The communication device 617 is disposed above the above water level surface 620a of the floating body 620. The communication device 617 is configured to wirelessly communicate with the control module 514, and is configured to communicate with the submersible propulsion units 616 via the electrical wires W1 and W2.

[0162] As mentioned above, each of the submersible propulsion units 616 includes the the battery unit 48' shown in FIG. 22. Accordingly, each of the submersible propulsion units 616 includes at least one battery (i.e., the batteries 66) that supplies power to the communication device 617. In particular, the electrical wires W1 and W2 supply electrical power from the batteries 66 to the communication device 617. Thus, the electrical wires W1 and W2 transmits both command signals and electrical power. The electrical wires W1 and W2 can use dedicated signal lines for transmitting the command signals, or the power lines can be used to transmits both command signals and electrical power using power line communications (PLC).

[0163] Referring to FIGS. 45 and 46, an aquatic jet propulsion device 710 is provided on the aquatic vessel 612 in accordance with another illustrated embodiment. Here, the aquatic jet propulsion device 710 is identical to the aquatic jet propulsion device 610, except that the communication device 617 has been replaced with a communication device 717. The communication device 717 is identical to the communication device 617, except that the housing of the communication device 717 is enlarged to accommodate an auxiliary battery AB that supplies power to the batteries of the submersible propulsion units 616 via the electrical wires W1 and W2. The communication device 717 also preferably includes the vessel mount 517a for mounting the communication device 717 to the above water level surface 620a of the floating body 620.

[0164] Referring to FIGS. 47 and 48, an aquatic jet propulsion device 810 is provided on the aquatic vessel 612 in accordance with another illustrated embodiment. Here, the aquatic jet propulsion device 810 is identical to the aquatic jet propulsion device 610, except that the aquatic jet propulsion device 810 further includes an auxiliary battery AB. The auxiliary battery AB is detachably and reattachably attached to the above water level surface 620a of the floating body 620 outside the housing of the communication device 617. The auxiliary battery AB is externally provided relative to the communication device 617. The auxiliary battery AB is electrically connected to the communication device 617 via an electrical wire W3. The auxiliary battery AB supplies power to the batteries of the submersible propulsion units 616 via the electrical wires W1 and W2. With this configuration, the user can additionally connect the auxiliary battery AB to the communication device 617 when the user wants to have an additional battery capacity additional to the batteries of the submersible propulsion units 616.

[0165] Now, the paddle 518 will be discussed in more detail with reference to FIGS. 49 to 51. As mentioned above, the paddle 518 includes the control module 514, which can be used to operate any one of the aquatic jet propulsion device as discussed above. In other words, the control module 514 of the paddle 518 can be used to wirelessly send and receive control signals directly to and from the submersible propulsion units 16A, 16B, 216A, 216B, 416A and 416B or via one of the communication devices 70', 517, 517', 617 and 717.

[0166] The stand up paddle 518 comprises a shaft 518a, a first blade 518b disposed at a first end of the shaft 518a and a grip 518c disposed at a second end of the shaft 518a. The control module 514 is disposed on the shaft 518a. As seen in FIGS. 50 and 51, the control module 514 includes a paddle attachment 522 that is configured to be attached around a portion of the shaft 518a. The paddle attachment 522 also functions control module housing, since the paddle attachment 522 housings the controller 540, the wireless communication device 542 and the battery 544. The display 538 is also disposed on the paddle attachment 522. The paddle attachment 522 is a generally annular member that is clamped on the shaft 518a. For example, the paddle attachment 522 can have two curved housing halves that are clamped together by two or more threaded fasteners. Alternatively, the two curved housing halves can be connected using a snap-fit construction. In any case, the paddle attachment 522 is firmly positioned on the shaft 518a so that there is no relative movement between the paddle attachment 522 and the shaft 518a of the paddle 518.

[0167] On the other hand, the first and second twistable inputs 526A and 526B are movably connected to the paddle attachment 522 such that the first and second twistable inputs 526A and 526B are configured to twist around a longitudinal axis CA of the shaft 518. Thus, by twisting the first twistable input 526A around the longitudinal axis CA of the shaft 518, the user can selectively increase and decrease the speed of the motors of the submersible propulsion units 616. On the other hand, by twisting the second twistable input 526B around the longitudinal axis CA of the shaft 518, the user can select an operation mode such as an "ON" mode, an "OFF" mode, a motor assist mode, a right turning mode, a left turning mode and a reverse mode. Preferably, the display 538 shows the speed of the aquatic vessel with the indicia (i.e., letters, numbers, symbols, etc.) being ori-

ented perpendicular to the longitudinal axis CA of the shaft 518. The display 538 preferably shown other operation conditions of the aquatic jet propulsion device such as a battery condition of the batteries of the submersible propulsion units 616, a leak condition of the submersible propulsion units 616, etc.

[0168] In the motor assist mode, the user can control the speed of the aquatic vessel using the first twistable input 526A as seen in FIG. 50. Alternatively, as seen in FIG. 51, the control module 514 includes a user input member M-SW that is disposed on the grip 518c of the paddle 518. The user input member M-SW can be an optionally feature that is pluggable into the first twistable input 526A, or a standard feature that is hard wired to the controller 540. In either case, the user input member M-SW is a grip detector that detects a grip state of the user input member M-SW by the user. The grip detector can be a pressure sensor or pressure activated switch, a capacitive grip detector, an infrared grip detector, and the like. For example, the motors of the submersible propulsion units 616 stop when the user is not gripping the user input member M-SW (e.g., when the user is not applying pressure to the user input member M-SW). On the other hand, the speed of the motors of the submersible propulsion units 616 are increases as the user more strongly grip the user input member M-SW (e.g., as the user increases pressure on the user input member M-SW). Thus, the control module 514 is configured to output a motor control based on operation of the user input member M-SW.

[0169] In the case of the control module 514 being mounted to the paddle 518, the control module 514 preferably includes at least one twistable input. However, the control module 514 to use other types of user inputs instead of or in conjunction with a twistable input. For example, the second twistable input 526B can be replaces with push buttons or touch screen buttons provided on the display 538.

[0170] Now, a kayak paddle 618 that uses the control module 514 will be discussed with reference to FIGS. 52 to 53. The kayak paddle 618 comprises a shaft 618a, a first blade 618b disposed at a first end of the shaft 618a and a second blade 618c disposed at a second end of the shaft 618a. The control module 514 is disposed on the shaft 618a in the same manner as in the case of the stand up paddle 518. However, the control module 514 is preferably disposed at a central area of the kayak paddle 618. When the control module 514 is installed on the kayak paddle 618, the user can set the controller 540 so that the display 538 shows the speed of the aquatic vessel with the indicia (i.e., letters, numbers, symbols, etc.) being oriented parallel to the longitudinal axis CA of the shaft 518.

[0171] Referring to FIGS. 54 and 55, a stand up paddle 518' that has an integrated control module 514' will now be discussed. The stand up paddle 518' comprises a shaft 518a', a first blade 518b' disposed at a first end of the shaft 518a' and a grip 518c' disposed at a second end of the shaft 518a'. Here, the integrated control module 514' is integrated into the grip 518c'. Specifically, the integrated control module 514' has a shaft portion 519' that includes the grip 518c'. The shaft portion 519' is used to attached to the shaft 518a' using a mounting collar 521'. Thus, the shaft portion 519' is configured to be attached as a part of the shaft 518a'. In this way, the grip 518c' with the integrated control module 514' is attached to an end of the shaft 518a'. The control module 514' further includes a user input member M-SW' that is disposed on the grip 518c' of the paddle 518'. The basic

construction of the integrated control module 514' is the same as the control module 514, as seen in FIG. 35, except for the integration of the integrated control module 514' to the shaft 518a' and the grip 518c' of the paddle 518'. More specifically, in the integrated control module 514', the paddle attachment 522 of the control module 514 has been replaced with a shaft portion 519' that is configured to be attached as a part of the shaft 518a' using the mounting collar 521'. In other words, the integrated control module 514' includes a user input interface 526', a display 538' an electronic controller (not shown), a wireless communication device (not shown) and a battery (not shown). Similar to the first and second twistable inputs 526A and 526B, the first and second twistable inputs 526A' and 526B' are movably connected to the shaft portion 519' such that the first and second twistable inputs 526A' and 526B' are configured to twist around a longitudinal axis CA of the shaft portion 519'. The display 538' is also disposed on the shaft portion 519'. Also, the shaft portion 519' housings the controller, the wireless communication device and the battery. Accordingly, the integrated control module 514' operates in the same manner as the control module 514 as discussed above. In view of the similarity of the control modules 514 and 514', the integrated control module 514' will not be discussed in further detail for the sake of brevity.

[0172] Referring to FIGS. 56 and 57, a kayak paddle 818' that has an integrated control module 814' will now be discussed. Basically, the integrated control module 814' is identical to the integrated control module 514', except that integrated control module 814' includes a center shaft portion 819' that is configured to form the center portion of the kayak paddle 818'. In particular, the stand up paddle 818' comprises a shaft 818a' that a first end shaft portion 818a1', a second end shaft portion 818a2' and the center shaft portion 819'. The kayak paddle 818' further includes a first blade 818b' disposed at a first end of the first end shaft portion 818a1' and a second blade 818c' disposed at a second end of the second end shaft portion 818a2'. Thus, the integrated control module 814' is integrated into the shaft 818a'. The basic construction of the integrated control module 814' is the same as the integrated control module 514', as discussed above, except that center shaft portion 819' is in the center of the shaft 818a' and does not include a grip. In other words, the integrated control module 814' includes a user input interface 826', a display 838' an electronic controller (not shown), a wireless communication device (not shown) and a battery (not shown). Similar to the first and second twistable inputs 526A' and 526B', the first and second twistable inputs 826A' and 826B' are movably connected to the shaft portion 819' such that the first and second twistable inputs 826A' and 826B' are configured to twist around a longitudinal axis CA of the shaft portion 819'. The display 838' is also disposed on the shaft portion 819'. Also, the shaft portion 819' housings the controller, the wireless communication device and the battery. Accordingly, the integrated control module 814' operates in the same manner as the control module 514 as discussed above. In view of the similarity of the control modules 514 and 814', the integrated control module 814' will not be discussed in further detail for the sake of brevity.

[0173] In understanding the scope of the present invention, the term "comprising" and its derivatives, as used herein, are intended to be open ended terms that specify the presence of the stated features, elements, components,

groups, integers, and/or steps, but do not exclude the presence of other unstated features, elements, components, groups, integers and/or steps. The foregoing also applies to words having similar meanings such as the terms, "including", "having" and their derivatives. Thus, as used herein, the singular forms "a," "an" and "the" are intended to include the plural forms as well, unless the context clearly indicates otherwise. Also, the terms "part," "section," "portion," "member" or "element" when used in the singular can have the dual meaning of a single part or a plurality of parts. Unless otherwise defined, all terms (including technical and scientific terms) used herein have the same meaning as commonly understood by one of ordinary skill in the field of aquatic jet propulsion devices to which illustrative embodiments of the inventive concepts belong. It will be further understood that terms, such as those defined in commonly-used dictionaries, should be interpreted as having a meaning that is consistent with their meaning in the context of the relevant art and will not be interpreted in an idealized or overly formal sense unless expressly so defined herein.

[0174] It will be understood that when an element is referred to as being "connected" or "coupled" to another element, it can be directly connected or coupled to the other element or intervening elements may be present. In contrast, when an element is referred to as being "directly connected" or "directly coupled" to another element, there are no intervening elements present. As used herein the term "and/or" includes any and all combinations of one or more of the associated listed items. Additionally, similar words used to describe the relationship between elements or layers should be interpreted in a like fashion (e.g., "between" versus "directly between", "above" versus "directly above", "below" versus "directly below", "adjacent" versus "directly adjacent", "on" versus "directly on"). Thus, components that are shown directly connected or contacting each other can have intermediate structures disposed between them unless specified otherwise.

[0175] It will be understood that, although the terms "first", "second", etc. may be used herein to describe various elements, components, regions, layers, positions and/or sections, these elements, components, regions, layers, positions and/or sections should not be limited by these terms. These terms are only used to distinguish one element, component, region, layer, position or section from another element, component, region, layer, position or section. Thus, a first element, component, region, layer, position or section discussed above could be termed a second element, component, region, layer, position or section without departing from the teachings of illustrative embodiments.

[0176] Spatially relative terms, such as "forward", "rearward", "above", "below", "beneath", "downward", "vertical", "horizontal", and "transverse" as well as any other similar spatial terms may be used herein for the ease of description to describe one element or feature's relationship to another element(s) or feature(s) of the above embodiments. These terms, as utilized to describe the present invention should be interpreted relative to an aquatic vessel floating in calm water.

[0177] The terms of degree such as "substantially", "about" and "approximately" as used herein mean an amount of deviation of the modified term such that the end result is not significantly changed.

[0178] While only selected embodiments have been chosen to illustrate the present invention, it will be apparent to

those skilled in the field of aquatic jet propulsion devices from this disclosure that various changes and modifications can be made herein without departing from the scope of the invention as defined in the appended claims. The structures and functions of one embodiment can be adopted in another embodiment. It is not necessary for all advantages to be present in a particular embodiment at the same time. Every feature which is unique from the prior art, alone or in combination with other features, also should be considered a separate description of further inventions by the applicant, including the structural and/or functional concepts embodied by such feature(s). Thus, the foregoing descriptions of the embodiments according to the present invention are provided for illustration only, and not for the purpose of limiting the invention as defined by the appended claims and their equivalents.

What is claimed is:

1. An aquatic vessel comprising:
  - a floating body having an above water level surface and a below water level surface;
  - a submersible propulsion unit disposed on the floating body beneath the below water level surface of the floating body; and
  - a communication device disposed on the floating body above the above water level surface of the floating body, the communication device being wired to the submersible propulsion unit and being configured to wirelessly communicate with a control module.
2. The aquatic vessel according to claim 1, further comprising another second submersible propulsion unit disposed on the floating body beneath the below water level surface of the floating body, and wired to the communication device.
3. The aquatic vessel according to claim 1, further comprising a tether having a first end detachably mounted to the communication device and a second end having a user attachment, the submersible propulsion unit being configured to stop propulsion of the submersible propulsion unit upon the tether being detached from the communication device.
4. The aquatic vessel according to claim 1, wherein the communication device includes a vessel mount attached to the floating body, and a housing having communication circuit and an antenna, the housing is detachably and reattachably coupled to the floating body.
5. The aquatic vessel according to claim 1, wherein the submersible propulsion unit includes at least one battery that supplies power to the communication device.
6. The aquatic vessel according to claim 1, wherein the submersible propulsion unit includes at least one housing containing a motor and a battery electrically connected to the motor.
7. The aquatic vessel according to claim 6, wherein the communication device includes an auxiliary battery that supplies power to the battery of the submersible propulsion unit.
8. The aquatic vessel according to claim 6, further comprising

an auxiliary battery configured to supply power to the battery of the submersible propulsion unit, the auxiliary battery being externally provided relative to the communication device.

9. The aquatic vessel according to claim 1, further comprising the control module including a controller and a wireless communication device.
10. A paddle comprising:
  - a shaft;
  - a first blade disposed at a first end of the shaft; and
  - a control module disposed on the shaft, the control module including a controller and a wireless communication device.
11. The paddle according to claim 10, wherein the control module includes a paddle attachment that is configured to be attached around a portion of the shaft.
12. The paddle according to claim 10, wherein the control module includes a shaft portion that is configured to be attached as a part of the shaft.
13. The paddle according to claim 10, wherein the control module includes a user input interface.
14. The paddle according to claim 10, wherein the user input interface includes at least one twistable input that is configured to twist around a longitudinal axis of the shaft.
15. The paddle according to claim 10, wherein the user input interface includes a display.
16. The paddle according to claim 10, further comprising a grip disposed at a second end of the shaft; and the control module includes a user input member on the grip.
17. The paddle according to claim 16, wherein the control module includes a user input member on the grip, the control module being configured to output a motor control based on operation of the user input member.
18. The paddle according to claim 10, further comprising a second blade disposed at a second end of the shaft.
19. An aquatic vessel comprising:
  - a paddle including a control module having a controller and a wireless communication device;
  - a floating body having an above water level surface and a below water level surface;
  - a submersible propulsion unit disposed beneath the below water level surface of the floating body; and
  - a communication device disposed above the above water level surface of the floating body, the communication device being configured to wirelessly communicate with the control module, and being configured to communicate with the submersible propulsion unit.
20. The aquatic vessel according to claim 1, wherein the communication device is wired to the submersible propulsion unit to conduct communications from the communication device to the submersible propulsion unit.
21. The aquatic vessel according to claim 1, wherein the submersible propulsion unit includes a wireless communication device that wirelessly receives communications from the communication device.